

TR 570 / TR 830 / TR 1100

Installation, Operation and Maintenance Instructions

– Read and Save These Instructions –

This manual is provided to acquaint you with the dehumidifier so that installation, operation and maintenance can proceed successfully. Ultimate satisfaction depends on the quality of installation and a thorough understanding of this equipment. The dehumidifier is built around tested engineering principles and has passed a thorough inspection for quality of workmanship and function.



4201 Lien Rd
Madison, WI 53704
www.QuestClimate.com

Toll-Free 1-877-420-1330
info@QuestClimate.com

Table of Contents

Notes regarding the instructions1
 Safety2
 Information about the device..... 4
 Transport and installation.....9
 Assembly and installation10
 Start-up 13
 Operation14
 Errors and faults 15
 Maintenance18
 Harmful influences on rotors 21
 Disposal 22
 Options 23
 Technical annex..... 32

Notes regarding the instructions

Symbols



Warning of electrical voltage

This symbol indicates dangers to the life and health of persons due to electrical voltage.



Warning

This signal word indicates a hazard with an average risk level which, if not avoided, can result in serious injury or death.



Caution

This signal word indicates a hazard with a low risk level which, if not avoided, can result in minor or moderate injury.

Note

This signal word indicates important information (e.g. material damage), but does not indicate hazards.



Info

Information marked with this symbol helps you to carry out your tasks quickly and safely.



Follow the manual

Information marked with this symbol indicates that the instructions must be observed.



Wear hearing protection

Information marked with this symbol indicates that you should wear hearing protection.



Wear protective gloves

Information marked with this symbol indicates that you should wear protective gloves.



Wear foot protection

Information marked with this symbol indicates that you should wear safety boots.

You can download the current version of the instructions and the EU declaration of conformity via the following link:

<http://www.QuestClimate.com/manuals>



Safety

Read this manual carefully before starting or using the device. Always store the manual in the immediate vicinity of the device or its site of use!

WARNING

Read all safety warnings and all instructions. Failure to follow the warnings and instructions may result in electric shock, fire and / or serious injury. Save all warnings and instructions for future reference.

- Do not use the device in potentially explosive rooms.
- Do not use the device outside operating temperatures.
- Set the device up in an upright and stable position.
- Let the device dry out after a wet clean. Do not operate it when wet.
- Do not use the device with wet or damp hands.
- Do not expose the device to water spray.
- Never insert any objects or limbs into the running device.
- Do not cover or transport the device during operation.
- Do not sit on the device.
- Check accessories and connection parts for possible damage prior to every use of the device. Do not use any defective devices or device parts.
- Ensure that all electric cables outside of the device are protected from damage (e.g. caused by animals). Never use the device if electric cables or the power connection are damaged!
- The electrical connection must correspond to the specifications on the nameplate. Additionally, information regarding the electrical connection is provided in the technical annex.
- Observe the device's power input, cable length and intended use when selecting extensions to the power cable. Completely unroll extension cables. Avoid electrical overload.
- Before maintenance, care or repair work disconnect the device from the mains and secure it against unauthorized restart.
- Before carrying out maintenance, care or repair work on the device, remove the mains plug from the mains socket. Hold onto the mains plug while doing so.

- Do not under any circumstances use the device if you detect damages on the mains plug or power cable.
- If the supply cord is damaged, it must be replaced by the manufacturer, its service agent or similarly qualified persons in order to avoid a hazard.
- Defective power cables pose a serious health risk!
- When positioning the device, observe the minimum distances from walls and other objects as well as the storage and operating conditions specified in the technical annex.
- Make sure that the air inlet and outlet are not obstructed.
- Make sure that the suction side is kept free of dirt and loose objects.
- Do not remove any safety signs, stickers or labels from the device.
- Keep all safety signs, stickers and labels in legible condition.
- Before starting any internal work on the device, discharge the EMC filters, e.g. using load resistors.
- Only transport the device in an upright position.

Intended use

The desiccant dehumidifiers of the TR series are only to be used for dehumidifying atmospheric air. Any other use possibly exceeding the intended purpose is considered to be improper use.

Intended use comprises:

- observing all the information in the instructions
- compliance with the inspection and maintenance tasks
- observing the permissible operating and surrounding conditions according to the technical data (see Technical annex).

The following minimum requirements must be met:

- permissible ambient temperature: -4° F to +104° F
- relative humidity: max. 95 % RH non-condensing

After consultation with Quest other operating conditions are possible with respectively modified versions.

Improper use

Read this manual carefully before starting or using the device. Always store the manual in the immediate vicinity of the device or its site of use!

- Do not place unit in standing water.
- If supplying the system with contaminated air, the “harmful influences on rotors” must be observed!
- Do not expose the device to the weather without suitable protection.
- Any unauthorised modifications, alterations or structural changes to the device are forbidden.
- Any operation other than as described in this manual is prohibited. Non-observance renders all claims for liability and guarantee null and void.

Personnel qualifications

People who use this device must:

- be aware of the dangers that occur when working with electric devices in damp areas.
- have read and understood the instructions, especially the Safety chapter.

The following applies to the staff categories stated below:

Qualified Electrician

A qualified electrician must be able to read and understand electric circuit diagrams, to put electrical systems into service and to maintain them, to wire control cabinets, to ensure the functionality of electrical components and to identify possible hazards from electrical and electronic systems.

Personnel training

- Only trained and instructed personnel may work at or with the dehumidifier – observe the personnel qualifications.
- The responsibilities of the personnel for the following tasks must be clearly defined:
 - set-up and assembly
 - installation
 - start-up and operation
 - maintenance and repair
- The control unit may only be operated by instructed personnel.

Personal protective equipment



Warning of electrical voltage

Wear hearing protection when standing near the running device.



Wear protective gloves

For start-up, maintenance and troubleshooting always wear suitable protective gloves.



Wear foot protection

For transportation, start-up, maintenance and troubleshooting always wear suitable foot protection.

Personal protective equipment



Warning of electrical voltage

Work on the electrical components must only be carried out by a qualified electrician!



Warning of electrical voltage

Make sure to de-energize the device before starting work on electrical components. Set the main switch to the 0 position or pull the mains plug (if any) from the mains socket.



Warning

Dangers can occur at the device when it is used by untrained people in an unprofessional or improper way! Observe the personnel qualifications!



Warning

The device is not a toy and does not belong in the hands of children.



Warning

Risk of suffocation!

Do not leave the packaging lying around. Children may use it as a dangerous toy.

**Caution**

Only use residual current devices sensitive to all types of current (type B or B+). The integrated EMC filters can lead to instantaneously tripped RCDs. Use residual current devices with a minimum triggering level of > 300 mA and delayed tripping (type K).

Note

Do not operate the device without an inserted air filter! Without the air filter, the inside of the device will be heavily contaminated. This could reduce the performance and result in damage to the device.

Note

Dirt accumulating inside the rotor can substantially reduce the dehumidification performance or damage the rotor beyond repair. Supplying the system with contaminated air might damage the rotor. Observe the information regarding "Harmful influences on rotors".

Note

After a power failure the device will restart automatically provided that it was not switched off in the meantime. This behaviour is desired and necessary to ensure operation with little supervision.

Behaviour in the event of an emergency

1. Switch off the device.
2. In an emergency, disconnect the device from the mains feed-in:
Hold onto the mains plug while pulling the power cable out of the mains socket.
3. Do not reconnect a defective device to the mains.

Information about the device**General description**

Dehumidifiers operating on the desiccant principle are used to tackle drying tasks in the field of process engineering, air-conditioning, on construction sites, and for the dehumidification of production and storage facilities, where a particularly low humidity level is required over a broad temperature range. The desiccation technique enables the safe and economic operation even at low operating temperatures.

Design

The basic device consists of the following components:

- fans for air transport
- air filters behind every air inlet
- separate sectors for process air (to be dehumidified) and regeneration air (humid exhaust air)
- purging sector for heat recovery
- rotor desiccant wheel for the dehumidification with silica gel
- drive unit with gear motor, toothed belt pulley and toothed belt
- heater battery for heating regeneration air
- Depending on the selected options further components are possible (see Technical annex).

During dehumidification the desiccant wheel turns continuously at a low speed (depending on the configuration 2 to 40 rotations per hour).

The desiccant wheel is simultaneously interacting with the process and regeneration air so it can constantly absorb and release moisture.

Process air

The air to be dehumidified is brought in by means of a fan. The process air (4) flows through the desiccant wheel's dehumidification sector (1).

In doing so, the contained moisture is withdrawn by the sorbent (silica gel) and retained (desiccation). Due to physical processes the temperature of the dry air (6) increases. Later the dried air flows towards the dry air outlet.

Regeneration air

The regeneration air (5) is also brought in with its own fan and guided through the purging sector (3). During dehumidification the desiccant wheel warms up as a result of the released desiccation heat and the regeneration heat. The purging sector (3) serves the purpose of heat recovery and for cooling the desiccant wheel, leading to a reduced energy input and improvement of the dehumidification performance – especially at lower dew points. Air flowing through the heater (7) is heated to approx. 212° F to 280° F (depending on the intake temperature) and at the same time the relative humidity is extremely reduced.

In passing through the regeneration sector (2), the air reabsorbs the moisture retained by the silica gel (desorption). Then the extremely humid regeneration air (8) is discharged to the outside via the humid air outlet.

Schematic diagram

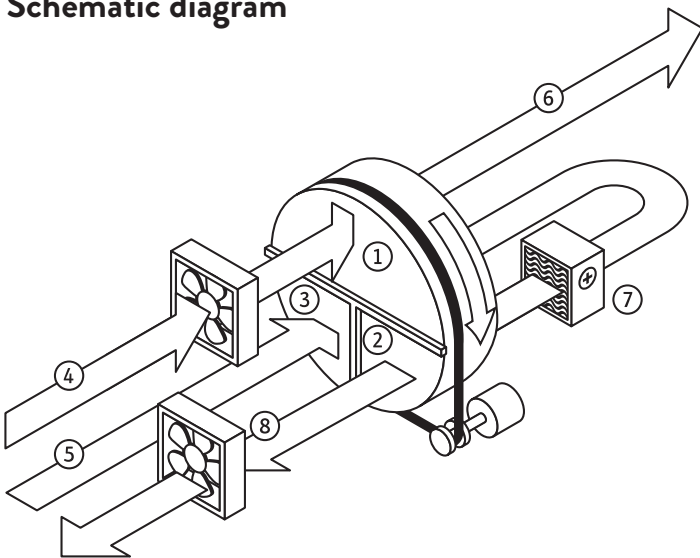

| No. | Designation |
|-----|-------------------------------------|
| 1 | Dehumidification sector |
| 2 | Regeneration sector |
| 3 | Purging sector |
| 4 | Process air inlet |
| 5 | Regeneration air inlet |
| 6 | Dry Air outlet |
| 7 | Heater battery |
| 8 | Humid air outlet (regeneration air) |

Design configuration and components

Rotor

The desiccant dehumidifier works with a desiccant wheel (rotor A) which is composed of layers of smooth and corrugated non-woven fabric with chemically bonded silica gel. Thus created is a honeycomb structure with a large number of axial air ducts with a large surface and direct connection to the inner pore structure of the silica gel.

On account of the desiccant wheel’s good mechanical and physical properties no silica gel is discharged. It may be supplied with saturated air with a relative humidity of up to 100 % but not with water drops. The rotor is incombustible.

Rotor drive

The rotor is driven by an electric gear motor.

The power is transmitted by means of synchronized pulley and timing belt.

Rotor rotation control

The device is equipped with a rotation sensor to warn of seized rotor condition.

Rotor bearing

The rotor is mounted on a stainless steel axle with maintenance-free bushings.

Rotor sealing

An automatically clearance-compensating gasket system seals the rotor and the individual air sectors against one another.

Filter

Air filters are located in each individual air inlet – depending on the field of application designed either as coarse or fine filter for removing the dust in the air currents.

Fans

Used are radial fans or mixed-flow fans with energy-saving EC motors. For an easy adjustment of the volumetric flow rates a potentiometer is located behind the front cover. The fan speed for process air and regeneration air can be adjusted according to the specifications.

Regeneration air heater

Heating the regeneration air is performed by electric heaters consisting of individual resistance heating elements. Depending on the dehumidifier model and size of the heater these can be designed as single- or multistage versions. The regeneration temperature is regulated by a thermostatic two-step control. Safety temperature monitors (STW) measure both the regeneration exhaust air temperature (RAL) and the regeneration air temperature heating (RHZ). Primarily the unit is regulated to a constant RHZ. With a decreasing moisture load however RAL might increase, so the heaters are reduced before reaching the RHZ.

Safety components

In order to protect the basic device from inadmissible temperatures, it comes equipped with the following safety components:

- a differential pressure switch (ΔP switch) to monitor the air flow direction and the flow rate of the regeneration air
- a safety temperature limiter (STB RHZ) to monitor the max. permissible temperature after heating (thermostat maximum)
- a safety temperature limiter (STB RAL) as rotation control for the
- rotor; it is situated in the exhaust air flow and tripped by an excessive temperature rise resulting from rotor standstill
- Depending on the selected options, additional features are possible (see Technical annex).

Note

If a safety component is tripped, the device will be switched off (STOP), but the overrun will remain active.

Wait until the entire rundown period has lapsed before accessing internal parts of the device.

Electrical system

The entire switching and control technology is located in the integrated electrical control box on the dryer housing. The electrical control box is designed for a high safety standard with protection type IP53 (see Technical annex).

Depending on the model, the terminals for remote monitoring and control can either be accessed via the front cover or the cover of the control box. This is also the place to access the reset buttons of the safety temperature limiters and the potentiometers for fan regulation. The cable gland for the mains feed-in is located at the side of the device. The power supply is connected directly to the terminals of the emergency stop main switch.

Housing

Depending on the model the housing of the dehumidifier is made of galvanized sheet steel or stainless steel sheet.

Options

There are additional options available for the desiccant dehumidifiers of the "TR..." series (see "Options" section).

Types of installation

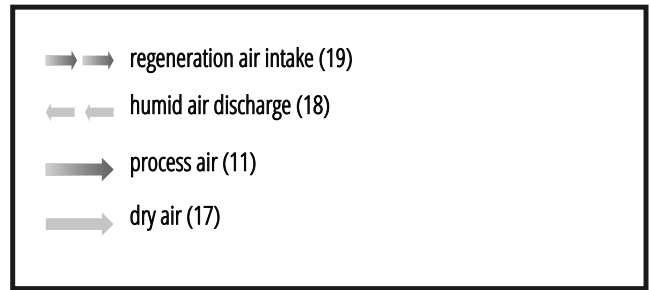

Installation within conditioned space

The device is positioned in the room to be dehumidified.

- The device operates in recirculation mode.
- The regeneration air inlet (19) is to be ducted from outside.
- The regeneration outlet is ducted outside.

Example 1

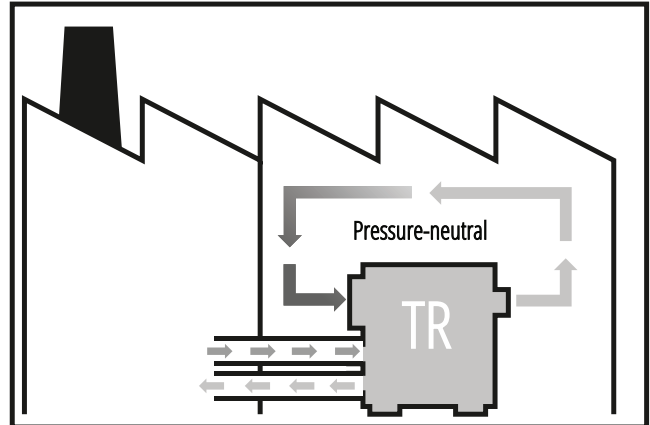

Installation outside conditioned space (neutral pressure)

The device is positioned in the room to be dehumidified.

- The process air inlet (17) is ducted from the room to be dried.
- The dry process air outlet (11) is ducted into the room.

Example 2

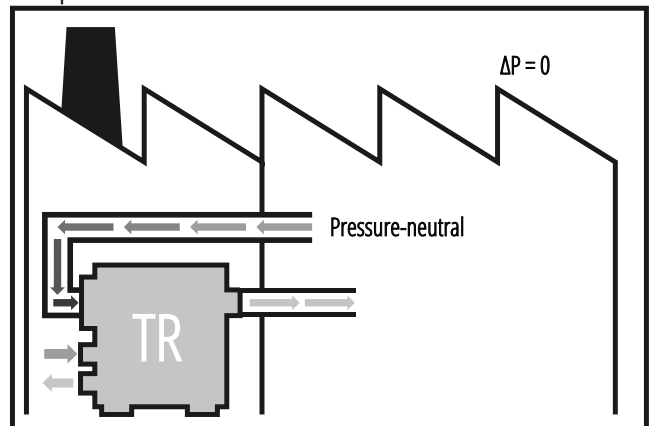

Installation outside conditioned space (positive pressure)

- The dry process air outlet (11) is ducted into the room to be dehumidified.

Example 3: Ventilation mode for outdoor installation

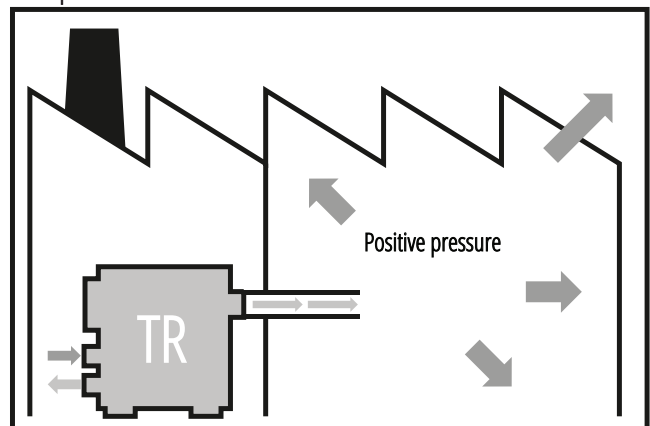

Device depiction

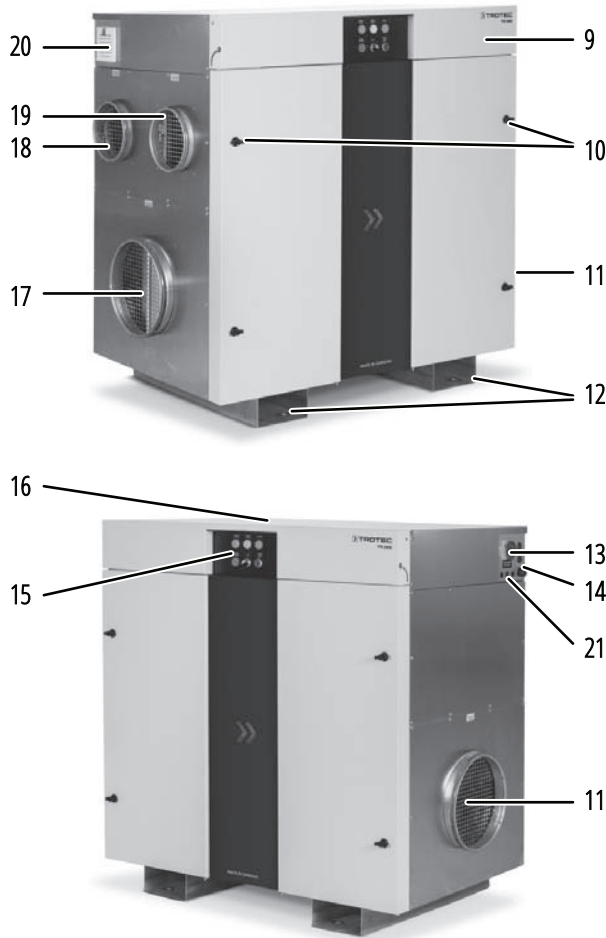

| No. | Designation |
|-----|--|
| 9 | Front cover (hinged) |
| 10 | Air filter access and maintenance doors |
| 11 | Process air outlet with duct connection |
| 12 | Forklift pockets |
| 13 | Main switch with emergency stop function |
| 14 | Cable gland for mains cable |
| 15 | Control panel |
| 16 | Electrical control box cover |
| 17 | Process air inlet with duct connection |
| 18 | Humid air outlet (regeneration air) with duct connection |
| 19 | Regeneration air inlet with duct connection |
| 20 | Control box ventilation system incl. air filter(s) |
| 21 | Cable inlet for control lines |

Product labelling

For an unmistakable identification, the desiccant dehumidifier is provided with a nameplate.

The nameplate is located inside the control box and in the area of the cable inlet.

The nameplate bears a UL mark. (Units mfg. after 2020)

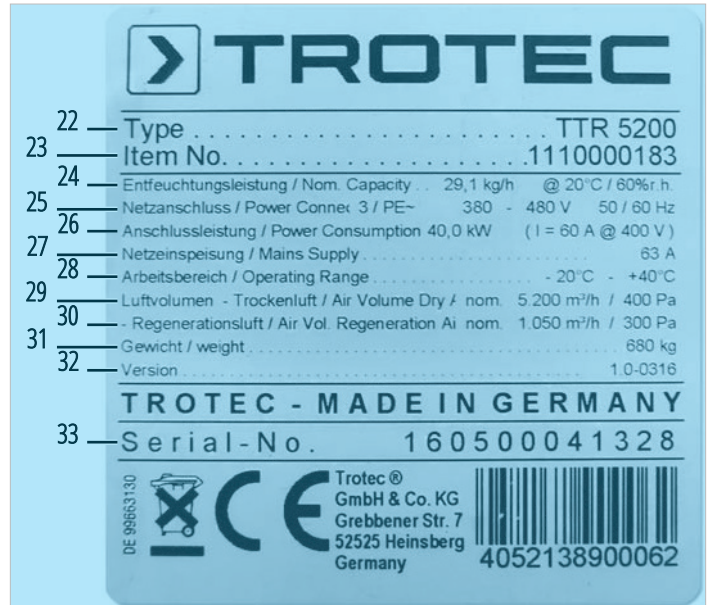

| No. | Designation | Unit |
|-----|---------------------------|--------------------------------|
| 22 | Type or device name | - |
| 23 | Quest item no. | - |
| 24 | Dehumidification capacity | [kg/h] @ 20 °C / 60 % RH |
| 25 | Power connection | - |
| 26 | Power consumption | P = [kW] I = [A] @ 400 V |
| 27 | Mains supply | [A] |
| 28 | Operating range | [°C] |
| 29 | Dry air volume | [m³/h] / [Pa] |
| 30 | Regeneration air volume | [m³/h] / [Pa] |
| 31 | Weight | [kg] |
| 32 | Version | - |
| 33 | Serial number | - |

Transport and installation



Warning

Risk of severe injuries due to falling device.

The device may only be lifted by use of the forklift pockets or lifting straps. Pipe sockets or other attachment parts must not be used as lifting points! The carrying capacity of the lifting gear must be suitable for the weight of the device (see Technical annex).

The following should be observed before transporting the device using lifting gear:



Warning

Risk of death due to suspended loads.

Make sure that nobody is situated in the immediate proximity!

- Only instructed persons are allowed to perform the transport by use of lifting gear.
- Consider the centre of gravity when transporting the load.

Installing the device

- Position the device on firm, dry and level ground.
 - Avoid slippery and unstable ground.
 - Position the device allowing a sufficient distance for air inlet and outlet and for connecting the ducting
 - Make sure there is enough space to operate and maintain the device (see Technical annex).
- Only install the device indoors. Make sure that no water can reach the device interior via the air inlet and outlet ducts. Optionally the device is delivered with weather protection equipment. Do not expose the device to the weather without this weather protection equipment.
- Ensure a sufficient distance between humid air outlet and air inlet.
- In case of direct-intake devices the distance between humid air outlet and the suction nozzles should amount to at least 2 m to prevent the humid exhaust air from being recirculated.
- The air ducts must be designed for the available static compression of the fans (see Technical annex).
- The regeneration exhaust air line (C) must be laid with a slight decline (min. 1.5 %) so that any accumulating condensate cannot flow back into the device or obstruct the air flow. If an incline cannot be avoided, it is necessary to deliberately create a drain trap.

Inserting the air filter

Note

To avoid damages to the device, do not operate the device without inserted air filters!

Prior to installation and switching the device on, check whether all air filters are inserted.

Information regarding the air filter installation and filter change can be found in the Maintenance chapter.

Schematic diagram

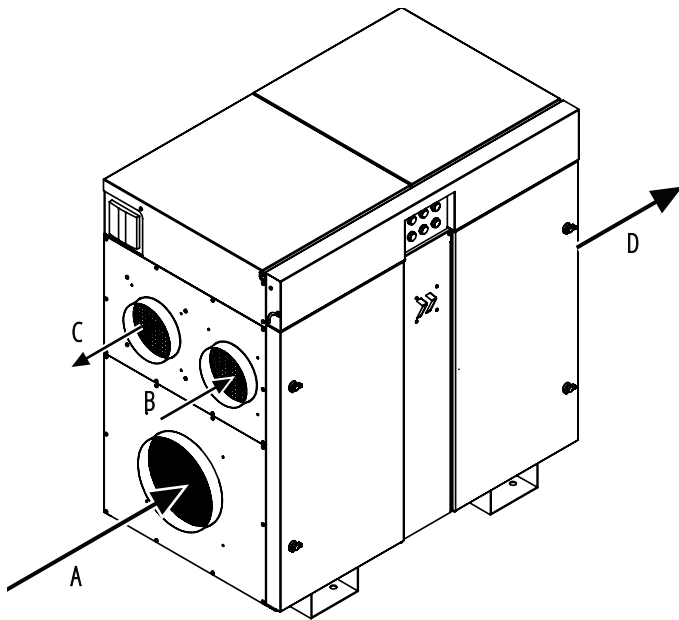

Optionally, a mirror-inverted assembly is also possible.

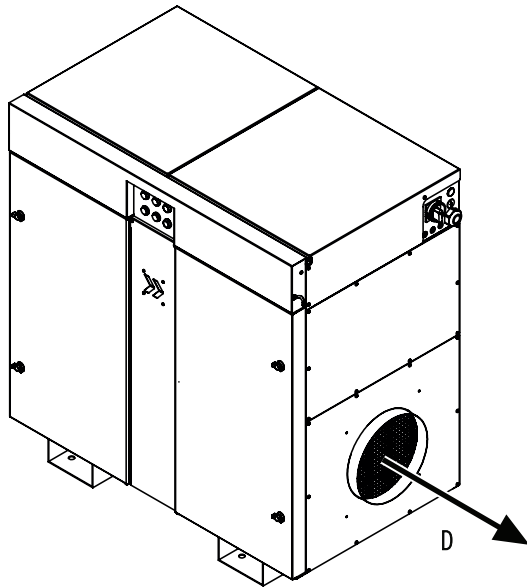

| No. | Designation |
|-----|-------------------------------------|
| A | Process air inlet |
| B | Regeneration air inlet |
| C | Humid air outlet (regeneration air) |
| D | Dry air outlet |

Assembly and installation

Power connection



Warning of electrical voltage

Work on the electrical components must only be carried out by a qualified electrician!

The illustrations below feature the series from the TR 190 through to the TR 1100 and can be used for all versions of the TR series. The mains supply terminals are situated directly at the main switch behind the main switch cover.

1. Loosen the two screws (34) of the front cover.

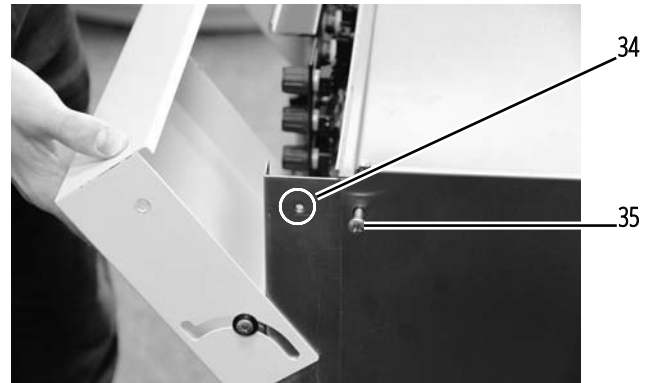

2. Slightly lift the front cover and open it.
3. Loosen the screws (35) of the electrical control box cover.
4. Remove the electrical control box cover either by pulling it forwards or by lifting it.

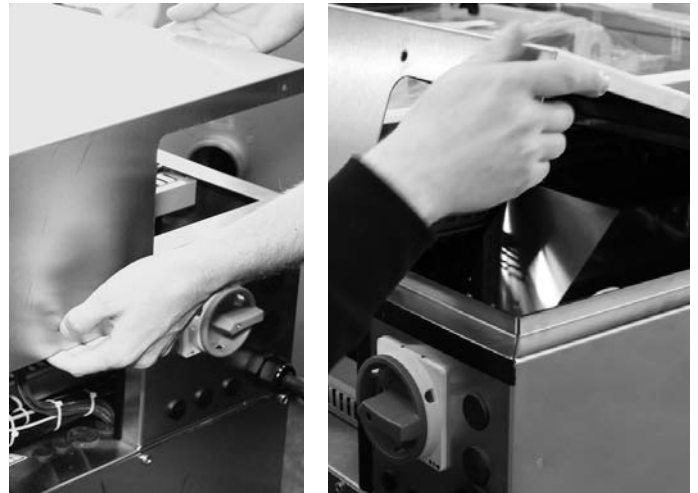

5. Guide your mains cable through the cable gland at the device and connect it to the power supply terminals. To connect the device please observe the wiring diagram in the technical annex. The phase sequence can be chosen freely.



6. Attach the cable, screw down the cable gland and check the strain relief.

In the device version shown below, the mains supply terminals are also situated directly at the main switch behind the main switch cover. The illustrations below feature the series from the TR 1500 through to the TR 3900:



1. Set the main switch to 0.
2. Loosen the screws and open the cover.
⇒ The cover can only be opened if the main switch is set to the 0 position!

3. Guide the mains cable through the cable gland at the device and connect it to the power supply terminals. To connect the device please observe the wiring diagram in the technical annex. The phase sequence can be chosen freely.

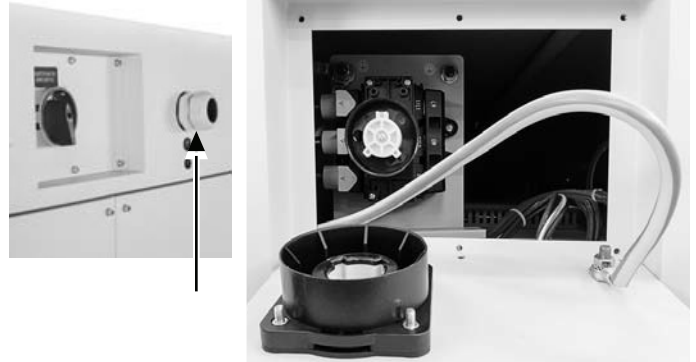

4. Fix the cable, screw down the cable gland and check the strain relief.

Connecting the control lines

Remote ON/OFF

If you want to operate the device optionally via remote mode, e.g. from a remote control or BMS system, connect the external switching contact (N/O contact) to the respective terminals. The control voltage amounts to 24 V DC (for detailed information please refer to the wiring diagrams in the technical annex).

Control via external hygrostat (% RH)

You can control the device via an external hygrostat (option). The control voltage amounts to 24 V DC.

The external hygrostat is to be connected to the terminal strip in accordance with the wiring diagram (see Technical annex).

If the relative humidity level falls below the set target value, the contact closes and terminates the dehumidification process.

The illustrations below show the terminals for remote switch-on and relays with potential-free contacts:



Ventilation mode process air

Select the operating mode “Ventilation mode process air” if constant air movement is required at times without the need for drying. Reposition the respective jumper (blue) to the corresponding terminals (for detailed information please refer to the wiring diagrams in the technical annex).

The process air fan keeps running even if the hygrostat switches off and the external contact of the hygrostat is opened.

Hygrostat and fan operation are only switches off when switching of the device (STOP), the fan will be switched off at the end of the rundown period.

You can always change back to the normal dehumidification mode by reversing the jumper.

Remote signalling contacts

Remote signalling is effected by means of potential-free changeover contacts that can be tapped directly at the corresponding relays.

1. BETRIEB / OPERATION
2. STÖRUNG / FAULT
3. FILTER / WARNING

These remote signalling contacts correlate with the lamps on the control panel (see description in the Operation chapter).

For the correct assignment observe the wiring diagrams in the technical annex.

Inserting the air filter

Check whether all air filters are inserted before switching the device on for the first time. The illustrations below are schematic representations:

1. Open the left door of the control cabinet.
2. Check whether the correct filters have been inserted in both the process air inlet and the regeneration air inlet (see Technical annex).

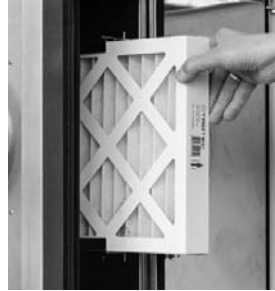

3. Check whether the filter for the control box ventilation system has been inserted:



Start-up

Requirements

- Check all air filters have been installed properly.
- Check all doors, flaps and covers are closed or screwed in place.
- Check that ducts have been connected and screwed down properly and secured by means of tension belts.
- Check all ducts are clear and free from foreign objects or obstacles.
- Check the permissible operating conditions according to the technical data.



Warning of electrical voltage

Work on the electrical components must only be carried out by a qualified electrician!
 Make sure that the electric installation complies with the technical documentation.
 Ensure the continuity of the protective conductor system.

Initial start-up

If the “Flowmatic S” option is installed, continue with step 4.
 For ideal operation, the regeneration air flow must be adjusted according to the technical data.

The potentiometers can be accessed via the front cover:

- target value fan speed process air (Proz.) and
- target value fan speed regeneration air (Reg.) for adjusting the air volume via the fan speed.

For adjustment work, measurements or the like, which have to be carried out during operation, one must switch over to manual operation (ON-SITE)!

Machine must be in manual mode for any adjustments to be made while machine is running.

1. Turn the selection switch to position I.
2. Open the front cover (9).
 ⇒ The two potentiometers are located behind the front cover on the right-hand side:
 - target value fan speed process air (Proz.) and
 - target value fan speed regeneration air (Reg.) for adjusting the air volume according to the information provided in the technical annex.



3. Adjust the regeneration air volume in manual mode.
4. Proceed with normal start-up.

Operation

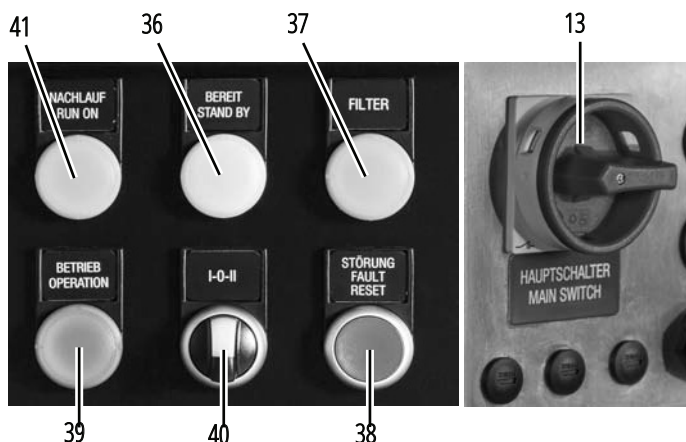

| No. | Designation |
|-----|--|
| 39 | BETRIEB / OPERATION lamp Indicates the device is operational |
| 40 | Selection switch MANUAL/REMOTE OPERATION I - 0 - II I: MANUAL OPERATION II: REMOTE OPERATION 0: Control OFF (STOP) |
| 41 | NAUCHLAUF / COOL DOWN Lamp Indicates the cool down operation of the device at operating temperature after switching off the control voltage. |

Note:

The main switch serves for switch-on and may only be used as emergency stop switch for disconnection from the mains in case of an emergency.



Warning

In order to prevent a damage to the heaters due to heat accumulation or an unnecessary tripping of the safety temperature limiter STB when switching off the unit, the regeneration air blower is provided with a temperature-controlled cool down period of approx. 5 minutes.

Wait until the entire cool down period has lapsed before accessing internal parts of the device.

For normal switch-off (STOP) please use the selection switch ON-SITE/REMOTE OPERATION I - 0 - II (40), which initiates the cool down function (NACHLAUF / RUN ON lamp (41) illuminated). Only disconnect the device from the mains for transport or storage via the main switch **at the end of the cool down period.**

Switching the device on

- ✓ The device is connected to the properly fused feed-in.
- 1. Turn the main switch (13) to position I.
- 2. Select the desired operating mode via the selection switch I - 0 - II (40):
 - ⇒ A) manual operation I
Turn the selection switch to position I: the BETRIEB / OPERATION lamp (39) is illuminated – the device starts up.
 - ⇒ B) remote operation II
Turn the selection switch to position II: the BEREIT / STAND BY lamp (36) is illuminated until the REMOTE-ON contact is activated – as soon as the REMOTE-ON contact has been activated, the BETRIEB / OPERATION lamp (39) will be illuminated – the device starts up.

| No. | Designation |
|-----|---|
| 13 | Main switch with emergency stop function 0: The device is switched off. I: The device is switched on. |
| 36 | BEREIT / STAND BY lamp Indicates operational readiness for REMOTE operation: –mains voltage present –selection switch in position II – REMOTE OPERATION –REMOTE-ON not yet activated |
| 37 | FILTER lamp Indicates the insufficient air flow rate of one or more air filters. The differential pressure controllers monitor the air flow rate of the filters to report a dirty filter. Replace a dirty filter to prevent impaired performance. |
| 38 | STÖRUNG / FAULT lamp and RESET button Fault message and device switched off (STOP) tripped by –a safety temperature limiter (STB RHZ) to monitor the max. permissible temperature after heating (thermostat maximum) –a safety temperature limiter (STB RAL) as rotation control for the rotor; it is situated in the exhaust air flow and tripped by an inadmissible temperature rise resulting from rotor standstill –a differential pressure switch (ΔP switch) to monitor the air flow direction and the flow rate of the regeneration air –phase error, check the feed-in and fusing –motor fault of the fans regeneration air or process air –possibly collective fault messages of additional options (see Technical annex) |

Note

In order to achieve the full dehumidification performance and to prevent damages due to an insufficient regeneration air flow, the air volumes specified in the technical annex must be observed. Dirty air filters reduce the volumetric flow rate and must be replaced.

Switching the device on

- Turn the selection switch (40) to position 0 or open the REMOTE-ON contact.
 - ⇒ The BETRIEB / OPERATION lamp (39) goes out.
 - ⇒ The NACHLAUF / RUN ON lamp (41) is illuminated.
 - ⇒ The device switches over to cool down operation.

Cool down operation

In order to release the trapped heat from the heater, the regeneration air blower will continue to operate for approx. 5 min (temperature-controlled). The control unit remains active. During cool down the device may be restarted at any time. The fans start up smoothly, delayed by approx. 20 s the device switches into normal operation.

After the cool down period, the regeneration air blower stops, and the indicator lights go out.

Shutdown

For a complete switch-off, e.g. for transport or maintenance activities, switch the emergency stop main switch (13) to the 0 position at the end of the rundown period.

Storage

- Store the cleaned device in a dry location and protect it against dust.
- Before restarting the device, check the condition of the power cable.
- If in doubt, have the cable repaired or call the customer service.
- Have the device checked once a year by an electrician.

Errors and faults

If the fault indicator switches the device off (STOP), only the rundown operation remains active.

After having eliminated the cause of the fault, the fault message can be reset via the corresponding reset button.

- STB RHZ
- STB RAL

- Open the front cover and remove the respective cover of the reset buttons.

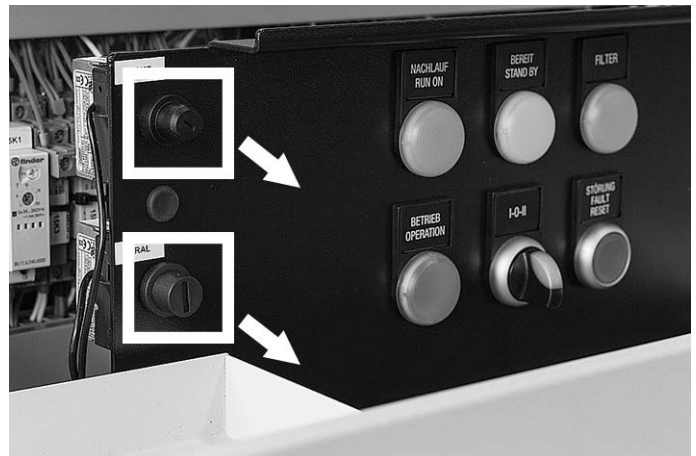

- Press the corresponding reset button and reattach the cover.



- Then press the STÖRUNG / FAULT - RESET button (38) to acknowledge the STB faults or the ΔP fault message.

Troubleshooting

| Fault | Cause of error | Resolution |
|--|--|--|
| "Fault" indicator light illuminated | <ul style="list-style-type: none"> rotation control (STB RAL) error rotor at a standstill process air flow interrupted regeneration air temperature too high | <ul style="list-style-type: none"> Check thermostat setting. Check rotor drive and toothed belt for proper functioning, repair if necessary. Check process air fan for proper function. Press reset button. |
| | <ul style="list-style-type: none"> thermostat (STB RHZ) error regeneration air flow interrupted regeneration air temperature too high | <ul style="list-style-type: none"> Check thermostat setting. Check regeneration air fan for proper function. Check filters. Press reset button. |
| | <ul style="list-style-type: none"> differential pressure switch for regeneration air does not switch | <ul style="list-style-type: none"> Check hose connection. Check setting, correct if necessary. Check pressure switch for proper functioning. |
| | <ul style="list-style-type: none"> fan does not rotate/fans do not rotate | <ul style="list-style-type: none"> See below. |
| Insufficient dehumidification performance | <ul style="list-style-type: none"> air flow imbalance | <ul style="list-style-type: none"> Calibrate air volumes. Check filters. Check housing (panels/doors) for air leaks. Check radial and circumferential seal at the rotor. Check rotational direction of fans. |
| | <ul style="list-style-type: none"> regeneration heating failed | <ul style="list-style-type: none"> Check heater for proper function, measure temperatures, have it replaced if necessary. Check fuses, replace them if necessary. Check relays, contactors, have them replaced if necessary. Check control thermostat setting. |
| | <ul style="list-style-type: none"> filter dirty | <ul style="list-style-type: none"> Change filter. |
| | <ul style="list-style-type: none"> process air flow interrupted | <ul style="list-style-type: none"> Check process air fan for proper function, have it replaced if necessary. Check air passages, flaps. |
| | <ul style="list-style-type: none"> rotor is not turning | <ul style="list-style-type: none"> Check belt/chain tension. Check drive motor for proper functioning, have it replaced if necessary. Check toothed belt pulley for tight fit, tighten if necessary. |
| <ul style="list-style-type: none"> incorrect rotor rotation direction | <ul style="list-style-type: none"> Correct rotational direction. | |

| Fault | Cause of error | Measure |
|---|--|---|
| Insufficient dehumidification performance | <ul style="list-style-type: none"> seals are not seated properly or are defective | <ul style="list-style-type: none"> Correct seal position (particularly radial seals) or replace them. |
| | <ul style="list-style-type: none"> air leaks at nozzles and fans | <ul style="list-style-type: none"> Eliminate air leaks. |
| | <ul style="list-style-type: none"> regeneration air flow interrupted | <ul style="list-style-type: none"> Check regeneration air fan for proper functioning. Check air passages, flaps. |
| | <ul style="list-style-type: none"> rotor defective | <ul style="list-style-type: none"> Have rotor replaced. |
| Fans do not rotate | <ul style="list-style-type: none"> electrical supply interrupted | <ul style="list-style-type: none"> Check and restore connection. |
| | <ul style="list-style-type: none"> phase missing | <ul style="list-style-type: none"> Check phases. |
| | <ul style="list-style-type: none"> impeller not fastened | <ul style="list-style-type: none"> Fasten impeller. |
| | <ul style="list-style-type: none"> motor defective | <ul style="list-style-type: none"> Have motor replaced. |
| Metallic sounds, rattling | <ul style="list-style-type: none"> fan impeller not fastened | <ul style="list-style-type: none"> Check process air and regeneration air fan, have them replaced if necessary. Fasten impeller. |
| | <ul style="list-style-type: none"> toothed belt or chain of rotor drive slips | <ul style="list-style-type: none"> Check toothed belt/chain tension. Check toothed washer/pinion and carrier (along rotor circumference) for damage. Check rotor for smooth running, replace bearing if necessary. |



Warning

This device can be dangerous if it is repaired by unqualified persons in an improper way. Any faults the elimination of which requires mechanical or electrical intervention may only be carried out by qualified specialists or service staff. If the fault cannot be rectified despite following the checklist above, please contact Quest at (877) 420-1330.

Maintenance

Activities required before starting maintenance

Warning of electrical voltage

Before starting any internal work on the device, switch the main switch to position 0. For disassembly a cool-down period of at least 30 minutes should be observed. Before starting any internal work, check that all motors and fans are at a standstill and that the device has cooled down.

Activities required before starting maintenance

- For any work carried out during operation, always switch over to manual operation (ON-SITE).
- If the dehumidifier was previously operated, wait for the end of the cool down period before switching the device off and for the end of the cool-down period of at least 30 minutes before disassembly.
- Secure all equipment up- and downstream from the dehumidifier against inadvertent start-up.
- For all maintenance, inspection and repair work, turn off the dehumidifier and secure the main switch against inadvertent restart.
- Attach a warning sign and secure the device against restart.

Notes on maintenance and repair activities

- Inform personnel before starting any maintenance and repair work.
- Upon completion of the maintenance work check all screwed connections for tight fit.
- Upon completion of the maintenance work check all safety devices for proper function.

Air filter change

The filter change intervals depend on the degree of air pollution and the filter quality. Dirty filters impair the performance of the dehumidifier.

A filter change is required at the latest when the filter change indicator FILTER on the control panel lights up.

Air filters for air inlet, dry air and regeneration air

1. Open the door for accessing the air filter behind the air inlets. In case of a standard version this means the left door of the cabinet; if mirror-inverted, use the right door.



2. Pull the filters for the individual air inlet openings out towards the front.

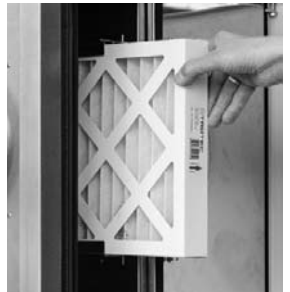

3. Change the filters as needed.



4. Then close the cabinet door again.



Air filters of the electrical control box

Check the air filter of the electrical control box once a month and replace the filter mat as needed.

1. To do so, open the filter flap at the electrical control box.



2. If it is dirty, replace the filter. Then close the flap again until it snaps into place.



General maintenance

Safe operation of the device requires the components listed below to be checked and cleaned **after 12 months at the latest or after every 4000 operating hours** as well as all damaged components to be replaced. Furthermore, an electrical safety test must be conducted.

If the device is used in an environment with increased dust exposure, we recommend performing a visual inspection during every air filter change.

| Component | Activity | Comments | Replacement / interval |
|--|-------------------|---|--------------------------|
| Differential pressure switch | Function test | Switching point | As required if defective |
| Gear motor | Function test | | 4,000 h |
| Solid-state relay SSR | Function test | Disconnection | As required |
| Power relay | Function test | Disconnection | As required |
| Emergency stop main switch | Function test | Disconnection of all phases | As required |
| Regeneration heating | Function test | Measure currents, clean surface if necessary | As required |
| Safety temperature limiter | Function test | Switching point, clean capillary tube | As required |
| Temperature probe | Function test | Check signals, clean probe | As required |
| Temperature monitor | Function test | Switching point, clean capillary tube | As required |
| Thermal switch NO 60 °C | Function test | Switching point | As required |
| Time relay | Function test | Time setting | As required |
| Air filter | Visual inspection | Check condition, replace if necessary | Filter indication |
| Filter fan | Visual inspection | Filter change, clean impeller | As required |
| Radial seals, desiccant wheel | Visual inspection | Check condition, replace if necessary | As required |
| Control cabinet | Visual inspection | Clean, blow out dust if necessary | As required |
| Desiccant wheel | Visual inspection | Obstructions, check surfaces for damage, replace if necessary | As required |
| Door seals | Visual inspection | Check condition, replace if necessary | As required |
| Circumferential seals, desiccant wheel | Visual inspection | Check condition, replace if necessary | As required |
| Regeneration air fan | Visual inspection | Clean impeller, check speed adjustment, measure currents | 4,000 h |
| Dry air fan | Visual inspection | Clean impeller, check speed adjustment, measure currents | 4,000 h |
| Toothed belt | Visual inspection | Check tension and condition, replace if necessary | As required |
| Screw terminal connections | Fit | Retighten if necessary | As required |
| Toothed belt pulley | Fit | Check connection to gear shaft | As required |

Care

Do not use a cleaning agents containing solvents to avoid damage to the surfaces and operating elements of the devices.

Clean the surfaces and operating elements of the devices with a damp cloth and solvent-free cleaning agents only.

Harmful materials on rotors

Some of the substances and compounds listed below are typical examples for substances dissolving the honeycombed silica gel rotors or else negatively affecting the dehumidification performance.

The sorption rotor should not be charged with air which is contaminated with the following or similar substances. Even minor concentrations in the air can have lasting harmful effects on the rotor material and the sorption capacity.

The listed substances remain in the rotor material or the rotor elements and can bring about the following effects:

- Reduced performance owing to the clogging of the silica gel's pores
- Reduced performance owing to the chemical reaction with the silica gel

A) Inorganic substances (examples)

| No. | Substances | Chemical formula | Effects |
|-----|-------------------------------|-------------------|--|
| 1 | lithium chloride | LiCl | reduced productivity of the silica gel ¹ |
| 2 | sodium hydroxide | NaOH | destruction of the silica gel structure |
| 3 | potassium hydroxide | KOH | destruction of the silica gel structure |
| 4 | sodium chloride | NaCl | reduced productivity of the silica gel ¹ |
| 5 | potassium chloride | KCl | reduced productivity of the silica gel ¹ |
| 6 | calcium chloride | CaCl ₂ | reduced productivity of the silica gel ¹ |
| 7 | magnesium chloride | MgCl ₂ | reduced productivity of the silica gel ¹ |
| 8 | ammonia | NH ₃ | destruction of the silica gel structure |
| 9 | hydrofluoric acid | HF | destruction of the mechanical strength of the rotor material |
| 10 | aluminium chloride | AlCl ₃ | reduced productivity of the silica gel ¹ |
| 11 | sea water | | reduced productivity of the silica gel ¹ |
| 12 | steam with a high temperature | | destruction of the silica gel structure |
| 13 | softener | | clogs the silica gel pores |
| 14 | strong acids | pH ≤ 2...3 | destruction of the mechanical strength of the rotor material |
| 15 | bases | pH ≥ 7...8 | destruction of the sorption capacity of the silica gel |
| 16 | amines | R-NH ₂ | reduced productivity of the silica gel ¹ |

B) Organic substances (examples)

The solvents or volatiles listed below have a high boiling point and a low vapour pressure. Provided these substances are adsorbed by silica gel, they remain in the material on a permanent basis.

| No. | Substances | Chemical formula | Effects |
|-----|--------------------|---|---|
| 1 | oil mist | | clogs the silica gel pores |
| 2 | cyclohexanone | C ₆ H ₁₀ O | reduced productivity of the silica gel ¹ |
| 3 | isopropyl alcohol | CH ₃ H ₈ O | reduced productivity of the silica gel ¹ |
| 4 | o-xylene | C ₈ H ₁₀ | reduced productivity of the silica gel ¹ |
| 5 | m-xylene | C ₈ H ₁₀ | reduced productivity of the silica gel ¹ |
| 6 | p-xylene | C ₈ H ₁₀ | reduced productivity of the silica gel ¹ |
| 7 | phenol | C ₆ H ₅ OH | reduced productivity of the silica gel ¹ |
| 8 | o-dichlorobenzenes | C ₆ H ₄ Cl ₂ | reduced productivity of the silica gel ¹ |
| 9 | methyl bromide | CH ₃ Br | reduced productivity of the silica gel ¹ |
| 10 | glycerin | C ₃ H ₈ O ₃ | reduced productivity of the silica gel ¹ |

¹⁾ Reduces the internal pore surface of the silica gel leading to a loss of performance.

**Warning****Potential environmental hazard due to incorrect disposal.**

Failure to follow the rules on disposal or an improper disposal of contaminated air filters can lead to environmental hazards.

In order to carry out the disposal professionally, you have to be a qualified specialist.

Recycle empty batteries.

Observe the currently applicable regional and, as the case may be, national disposal regulations.

Supplies

1. Shut down the desiccant dehumidifier.
2. Disconnect the desiccant dehumidifier from any supplies (current, water etc.).
3. Remove any materials such as air filters, oils, coolant, batteries etc.
4. Dispose of these materials separately according to the applicable regulations.

Components of the desiccant dehumidifier

The desiccant dehumidifier is composed of the following disposable materials:

- Steel, sheet steel, hardened steel, e.g. screws, motor shafts, component parts
- Different types of plastic, e.g. installation material, insulation material, window
- Rubber parts, e.g. seals and feet
- Plastic hoses
- Power cables, electric lines, electrical devices such as motors, controls, electronic components, electrical control elements, installation material, sensors

Final disassembly

For disassembly of the desiccant dehumidifier please proceed as follows:

1. Carefully disassemble the assemblies and parts that you want to continue to use in order to avoid damage to these parts.
2. Take notes so that you can re-assemble the used parts correctly.
3. Provide appropriate temporary storage facilities to be able to store the amounts of different materials separately.
4. Use any specified tools for disassembly: Remove fasteners to separate the parts from one another.
5. If possible, do not use any angle grinders or welding equipment as this would cause unnecessary additional effort.
6. After disassembly has been completed, have the parts collected by a qualified disposal company.
7. Store parts to be used again.

Options

Control module Millenium option

With four-line plain text display for status, warning and fault messages. The machine can be equipped with a freely programmable logic module offering the following functions:

Basic functions

- Function monitoring of fans, heating system and rotor drive
- All warnings or faults are displayed in plain text (for full particulars see chapter Errors and faults)
- Information regarding important basic settings and operating conditions (target and actual values) is displayed in plain text
- The energy management is optimized by a constant monitoring and continuous control of the regeneration temperatures RHZ and RAL

Factory options

- • continuous control of the outlet humidity level in partial-load operation (only in combination with a moisture measuring device and humidity control kit)
- continuous control of the outlet temperature of the dry air (only in combination with a temperature probe, temperature control kit, additional electrical heating or air/water heat exchanger with control valve)
- 2-stage air volume switching for reducing the outlet humidity level through a lower volumetric flow (only in combination with Flowmatic S)

The Millenium control module is located behind the left section of the front cover inside the electrical control box. To be able to read the control module's display, first open the front cover of the device (see instructions):

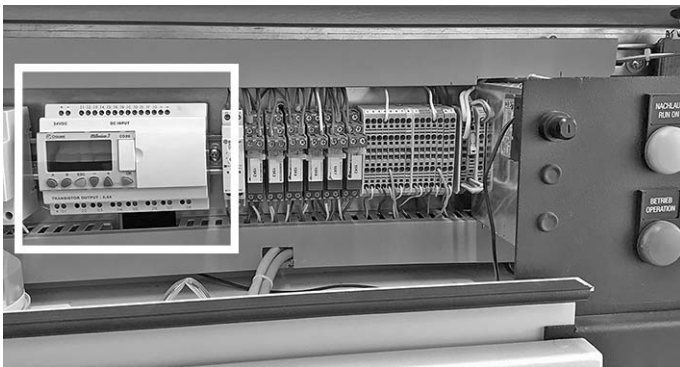

Operation

The PLC will be activated as soon as the main switch is switched on. The start screen (return) can be opened at any time by pressing the [ESC] button.

Returning to the start screen is also possible via the [B] button:



You can browse the screens using the buttons A and B. The following screens will be displayed:

- Welcome and version number.
- Indication of target and actual values for RHZ and
- RAL temperatures (humid air outlet).
- Indication of target and actual values for differential pressure, humidity level, dew point. The display may vary depending on the option installed.
- Indication of basic settings (distributed over several screen pages).
- Display of basic settings
- Target value inputs for optional additional heating and additional cooling.
- Target value input for optional switch-over to a lower dry air volume.

Operation screens of the control module Millennium



1. Start screen

In addition to the contact data this screen also shows the version number of the installed program of your Millennium.
Please quote this when contacting service.



2. Temperature screen

Display of maximum and actual values for the regeneration and exhaust air temperatures

| | |
|-------------|---|
| MAXIMUM RHZ | Target value regeneration air temperature |
| ACTUAL RHZ | Actual value regeneration air temperature |
| MAXIMUM RAL | Target value regeneration exhaust air temperature |
| ACTUAL RAL | Actual value regeneration exhaust air temperature |



3. Temperature and rotor screen

| | |
|------------|--|
| T-RHZ MIN | Minimum temperature of the regeneration air after completion of waiting period |
| DELAY-TIME | Waiting period in seconds |
| CHECKSUM | Counter for automatic switch-off when hot |
| ROTORSPEED | Current control value of the rotor speed [1/10 h] |



4. Relative humidity screen (optional)

| | |
|--------------|---|
| 1Ext/2Int/3P | Selection target value external = 1, internal = 2, control value external = 3 |
| ACT.Moist | Actual value humidity in [% RH] |
| SetP.Int. | Target value humidity in [% RH], can be modified |
| SetP.Ext. | Target value external humidity in [% RH], display only |



5. Dew point screen (optional)

| | |
|--------------|---|
| 1Ext/2Int/3P | Selection target value external = 1, internal = 2, control value external = 3 |
| ACT.Moist | Actual value humidity in [°Cdp] |
| SetP.Int. | Target value humidity in [°Cdp], can be modified |
| SetP.Ext. | Target value external humidity in [°Cdp], display only |

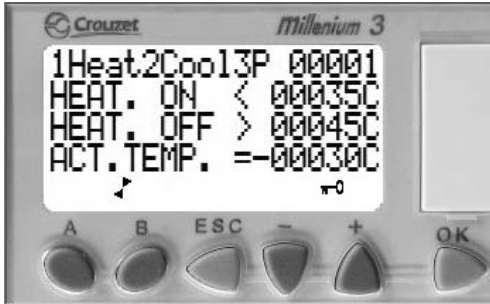

6. Process air regulation – additional heating screen (optional)

1Heat2Cool3P Heating = 1, cooling = 2, transmission external signal = 3

HEAT. ON Switch-on point for additional heating

HEAT. OFF Switch-off point for additional heating

ACT.TEMP. Actual value of the temperature sensor



7. Process air regulation screen (optional)

1Heat2Cool3P Heating = 1, cooling = 2, transmission external signal = 3

ACT.TEMP. Actual value of the temperature sensor

SetP.Int. Internal target value

>-20SetExt. External target value
Value above -20 °C = PLC switches over from internal to external target value.
Value below -20 °C = The internal target value applies.



8. Process air regulation screen (optional)

1Heat2Cool3P Heating = 1, cooling = 2, transmission external signal = 3

ACT.TEMP. Actual value of the temperature sensor

Stw In Ext. External control value

OutValveDry Output O6 PWM signal Control value for control valve



9. Dry air fan screen (optional)

Speed regulation of the process air fan if activated in the service menu

SWITCHPOINT Switching point input

SPEEDSTEP Display of high/low speed level

HIGH=0 / LOW=1 HIGH=0: high speed
LOW=1: low speed



10. Control valve regeneration heating screen (optional)

1Ext2Int3Pas Selection target value external = 1, internal = 2, control value external = 3

Set.RegValve External signal

Out.RegValve Output O6 PWM signal
Control value for control valve regeneration heating



Info

All optional displays only appear if the respective function was activated at the factory.

Basic settings

The basic settings are made in the factory. Signal conversions and the corresponding scales must be coordinated with Quest prior to delivery or can be adjusted (optionally) during start-up by Quest service personnel.

For applications with moisture control it is recommended to request the Quest service personnel for possibly required fine adjustments of the control parameters.

Changing values

- ✓ Values that can be modified are highlighted by flashing bars (black bar in the example below).

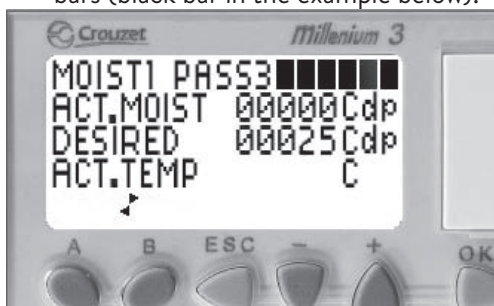

1. You can move up and down using the buttons + and -.
2. To edit the value, press the **OK** button.
⇒ The flashing bar disappears and the value is displayed.
3. Press + or - to increase or reduce the value.
4. Confirm your selection by pressing the **OK** button. Abort unwanted changes using **ESC**.
5. Press + or - to go to the next changeable value.
6. Repeat the steps 2 to 4 until all values are set.

Emergency operation

If the Millennium logic module fails, the following changes have to be made:

- Setting the regeneration air heating to emergency operation



Warning of electrical voltage

Work on the electrical components must only be carried out by a qualified electrician!

Please proceed as follows to set the regeneration air heating to emergency operation:

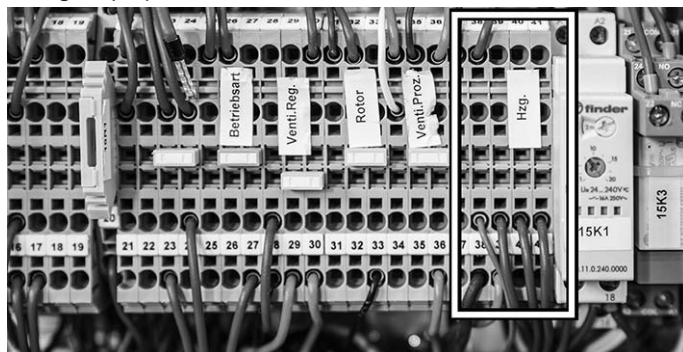

1. Locate terminals 5, 23 and 39 to 41 on the terminal strip X6.
2. Set the first jumper from X6.23 to X6.41 as shown below.

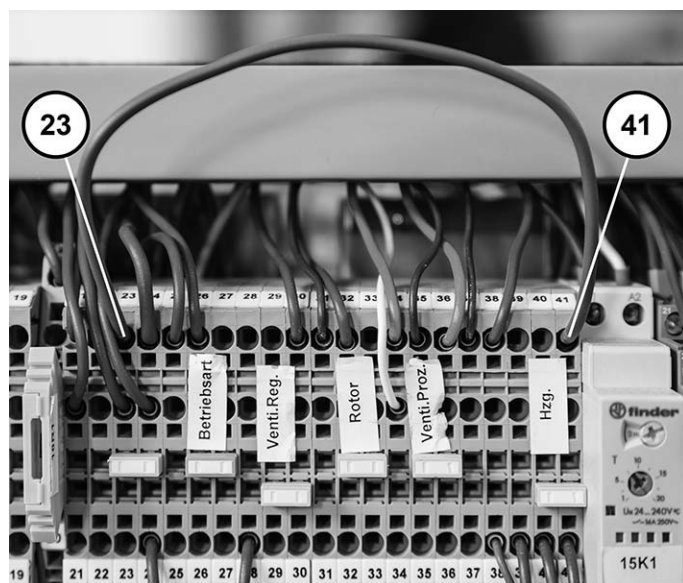

- Set the second jumper from X6.5 to X6.39 as shown below.

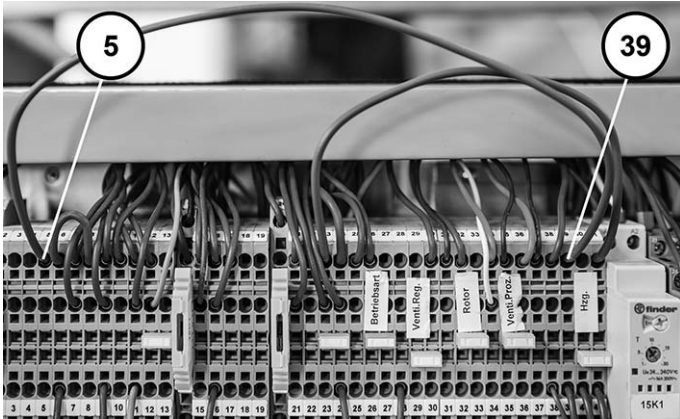

- In the second line from the bottom, disconnect the three wires of the contacts X6.39, X6.40, X6.41 as shown below.
- Isolate each of the three disconnected wires using a luster terminal or similar.

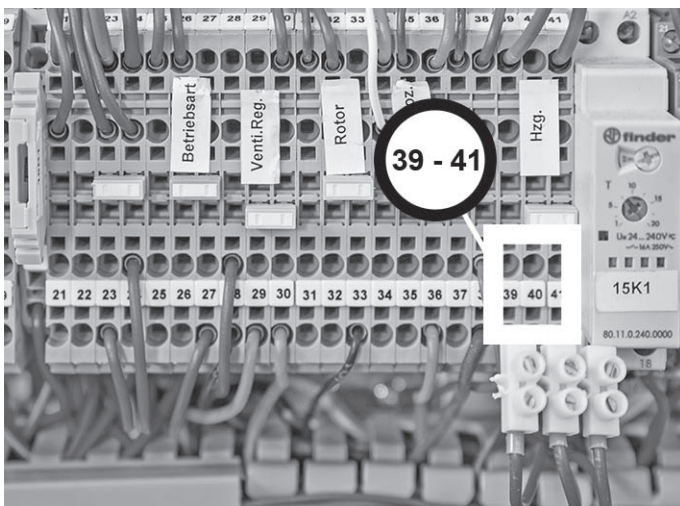

- Set a jumper from X6.40 to X6.41. The modifications are completed.

Warnings and faults

Note

Rectify any faults immediately to ensure economical operation of the device.

- During operation the electrical components relevant for the respective operating mode are monitored for proper functioning.
- In case of failure or malfunctions plain text messages are indicated on the display of the logic module so as to enable quick troubleshooting.
- Depending on the level of impairment of the device's operational safety the messages are divided into warnings and faults.
- A warning does not entail the shutdown of the device and is displayed by periodically recurring plain text messages on the display. The "warning" indicator light lights up.
- In case of faults the device is shut down (STOP) and the indicator light "fault" lights up.
- For safety reasons the device can only be restarted after the faults have been rectified and the RESET button has been actuated (=> deletes the error memory).

Error and fault messages can be reset by pressing the reset button.

Warnings

| Plain text message | Cause of error | Measure |
|--|---|---|
| FILTER WECHSELN (change filter) The differential pressure switches switch via the air filters when the max. permissible pressure drop is exceeded. | <ul style="list-style-type: none"> • filter dirty | <ul style="list-style-type: none"> • Replace all air filters. |
| HEIZUNG ZU KALT (heating too cold) After 30 min under full load the RHZ temperature must reach a value of at least 60 °C, in controlled operation the value is not prompted. | <ul style="list-style-type: none"> • regeneration air not reaching the minimum temperature • regeneration air volume too high • intake temperature too low • control signals interrupted | <ul style="list-style-type: none"> • Check heater current, if required, repair heater. • Check regeneration air volume. • Check switching devices and contacts. |
| WENIG REGEN.-LUFT (low airflow) Differential pressure switch monitors the pressure loss via regeneration heating and regeneration sector at the rotor and releases the heating when a minimum value is reached. | <ul style="list-style-type: none"> • regeneration air volume too low • regeneration air filter dirty • pressure loss in ducting • regeneration air fan defective or phases faulty • incorrect flow direction • negative pressure at regeneration air inlet too high | <ul style="list-style-type: none"> • Adjust the regeneration air volume. • Replace air filter. • Check ducting. • Check rotation. • Replace fan. |

Faults

| Plain text message | Cause of error | Measure |
|--|---|---|
| VENTI. PROZ.LUFT (fan process air) Fault message from EC motor | <ul style="list-style-type: none"> • fan reports a fault • fan defective • differential pressure transmitter defective • phase error/mains supply AC/DC | <ul style="list-style-type: none"> • Check fan, have it replaced if necessary. • Check wiring and contacts. • Check mains supply. • Adjust air volume. |
| VENTI. REGEN.LUFT (fan regeneration air) Fault message from EC motor | <ul style="list-style-type: none"> • fan reports a fault • phase error/mains supply AC/DC • fan defective | <ul style="list-style-type: none"> • Check fan, have it replaced if necessary. • Check wiring and contacts. • Check mains supply. |
| ROTOR-ANTRIEB (rotor drive) Rotor rotation control/inductive proximity switch is evaluated | <ul style="list-style-type: none"> • toothed belt slipping • toothed washer loosened • gear motor defective • fuse tripped | <ul style="list-style-type: none"> • Check belt tension and carrier. • Tighten toothed washer or have it replaced. • Check gear motor, have it replaced if necessary. • Check voltage supply and signal line of gear motor. |
| THERMOSTATE (thermostats) Safety temperature limiters (STB) are prompted. If an additional heating is used, the STB is prompted, too. | <ul style="list-style-type: none"> • At least one STB tripped. | <ul style="list-style-type: none"> • Check STBs for proper functioning, clean sensors if necessary. • Selected max. RHZ is too high. • Check setting at STB, adjust. • Check regeneration air volume. |

If the fault cannot be rectified, please contact Quest at (877) 420-1330



Flowmatic S option

The configuration of Flowmatic S depends on your application.



The regeneration air control is configured at the factory and does not require any further adjustment.

Target value setpoint: The process air is set via the “Venti. Proz.” potentiometer or an external target value.

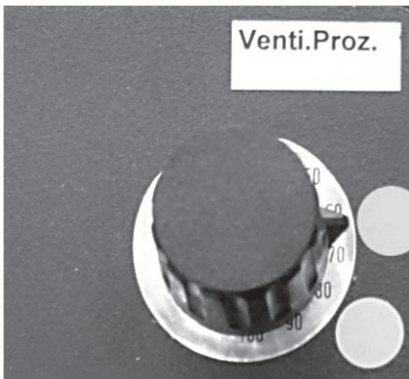

Actual value setpoint (Flowmatic S): Enter the desired target value at the Flowmatic S (▲ / ▼). For this purpose, keep changing the value until the desired value is shown on the display. The Flowmatic S will now adjust the value until the fan has reached its maximum speed.



Setting the target value:

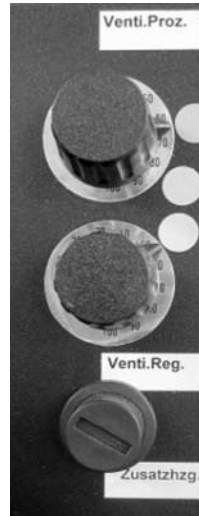

The upper “Venti.Proz.” potentiometer serves to define the target value for the process/dry air volume in m³/h.

The topmost point roughly marks the regulated nominal air volume and the point in the middle marks the nominal air volume in emergency operation. The points indicate the rough settings for emergency operation (failure of Flowmatic S).

Setting the actual value:

The default values are additionally indicated on a label attached to the Flowmatic S.

The settings for the actual value can be made in the Flowmatic S menu:

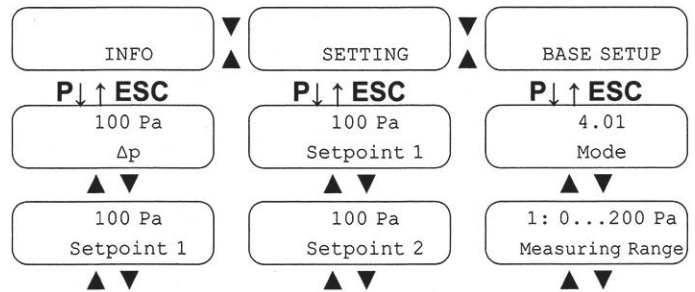

Note

If “Base Setup” is displayed, you have browsed too far through the menu. Press the “ESC” button in this case.

1. Press both buttons ▲ / ▼ simultaneously. The “INFO” menu will be displayed.
2. Press the ▼ button until the “SETTING” menu is displayed.
3. Press the “P” button.
4. Press the ▼ button until the “SETPOINT 1” menu is displayed.
5. Press the “P” button. The indication flashes.
6. Use the buttons ▲ / ▼ to reduce or increase the set value as desired.
7. Finally press the “P” button to save the settings for the new target value.

Operation without electric heating



Warning of electrical voltage

Work on the electrical components must only be carried out by a qualified electrician!

Should it be necessary to operate the desiccant dehumidifier without the electric reheater, simply reposition the jumper.

The jumper for manual changeover is located behind the front cover on the right-hand side.

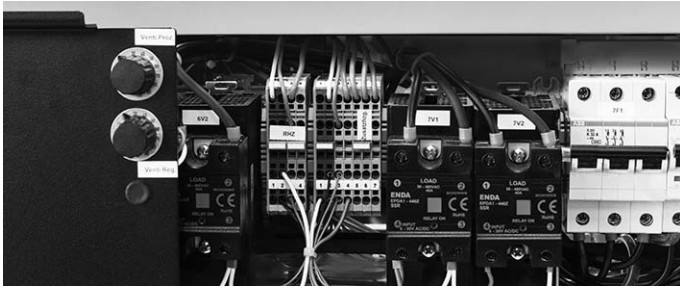

Weather protection equipment option

The weather protection equipment prevents the harmful penetration of rain water or similar and comprises:

- weather protection grids at air inlets
- additional seals
- exhaust pipe arc for humid air
- control panel protection

Note

Suitable on-site roofing or similar shall be provided in order to protect the device from a high solar irradiation (overheating) and snow loads (penetration of snowmelt).

Operation with electric heating

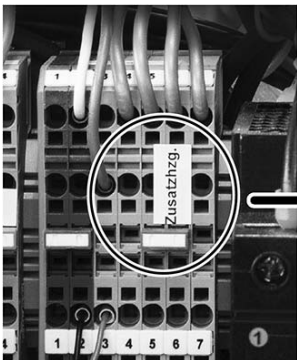

Operation without electric heating

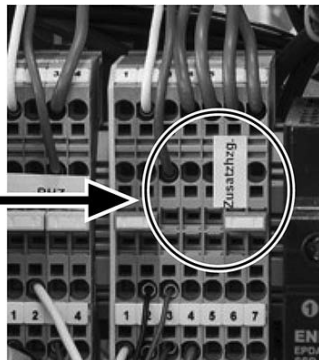

Equipment variant / variante de l'équipement: TA9720-Standard-02

ID for deviations or additional equipment from the standard device

ID pour les écarts ou les équipements supplémentaires par rapport à l'appareil de base

ELECTRICS / électricité

| | | |
|---|------------------------------|---|
| A | cover page | page de couverture |
| C | electrical feed | alimentation électrique |
| D | control voltage | tension de commande |
| E | switch cabinet cooling | refroidissement de l'armoire de commande |
| F | regeneration heater | chauffage de régénération |
| G | additional fan | ventilateur supplémentaire |
| H | regeneration air Fan | air de régénération Ventilateur |
| I | process air Fan | air de process Ventilateur |
| L | PLC controller | contrôleur PLC |
| M | control sensors | capteurs de contrôle |
| N | regeneration air fan control | commande du ventilateur d'air de régénération |
| O | process airflow display | affichage du débit d'air de process |
| P | processair fan control | commande du ventilateur processair |
| Q | moisture control | contrôle de l'humidité |
| R | process air external | air de process externe |
| S | temperature control | régulation thermique |
| T | hygrostat socket 4pol | prise hygostat 4 pôles |
| U | hygrostat socket 7pol | prise hygostat 7 pôles |
| V | electrical reheater | réchauffeur électrique |
| W | steam valve | vanne vapeur |
| X | water valve | vanne d'eau |
| Y | switch cabinet heater | radiateur d'armoire de commande |

MECHANICS / mécanique

| | | |
|-----|-------------------------------------|--|
| WTW | heat exchanger air/water | échangeur de chaleur air/eau |
| WTD | heat exchanger air/steam | échangeur de chaleur air/vapeur |
| GAS | gas burners | brûleurs au gaz |
| WSA | weatherproof equipment | équipement étanche |
| RO | swivel castors | roulettes pivotantes |
| ST | transport frame | châssis de transport |
| TRO | transport frame with swivel castors | châssis de transport avec roulettes pivotantes |

| Technical data | | TR570 | TR830 | TR1100 |
|--|------------|----------------------------|----------------------------|----------------------------|
| dehum. Capacity | lbs/day* | 570 | 830 | 1100 |
| dry air max. | CFM | 1383 | 1854 | 2530 |
| dry air nom. | CFM | 1177 | 1648 | 2530 |
| pressure | IWG | 1.2 | 1.2 | 1.2 |
| regeration air nom. | CFM | 223 | 335 | 435 |
| pressure | IWG | 1 | 1.2 | .8 |
| operation range airflows | --- | -4°F to 104°F 0-100%rh | -4°F to 104°F 0-100%rh | -4°F to 104°F 0-100%rh |
| operation range electrics | --- | -4°F to 104°F 0-95%rh | -4°F to 104°F 0-95%rh | -4°F to 104°F 0-95%rh |
| heater regeneration air (electr.) | kW | 12.5 | 18.9 | 24.5 |
| motors | kW | 2.5 | 2.7 | 4.3 |
| connect. Power | kW | 15.0 | 21.5 | 28.8 |
| voltage | V/Hz | 3PH/pe 380-480V 50-60Hz | 3PH/pe 380-480V 50-60Hz | 3PH/pe 380-480V 50-60Hz |
| current | A @400V | 21.7 | 31.0 | 41.6 |
| current connection | A | 32 | 32 | 63 |
| sound pressure level (without ducting) | Lp (dB)** | < 82** | < 82** | < 82** |
| weight | lbs | 510 | 550 | 600 |

* @68°C/60%rh

** distance 3ft. (@ max. fan speed), without piping

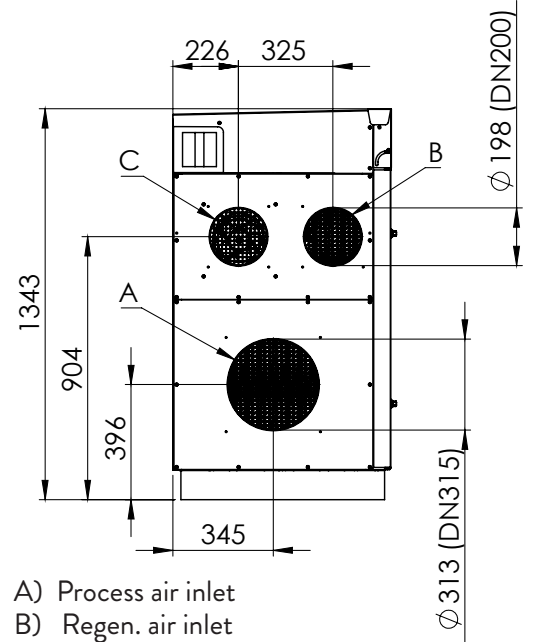
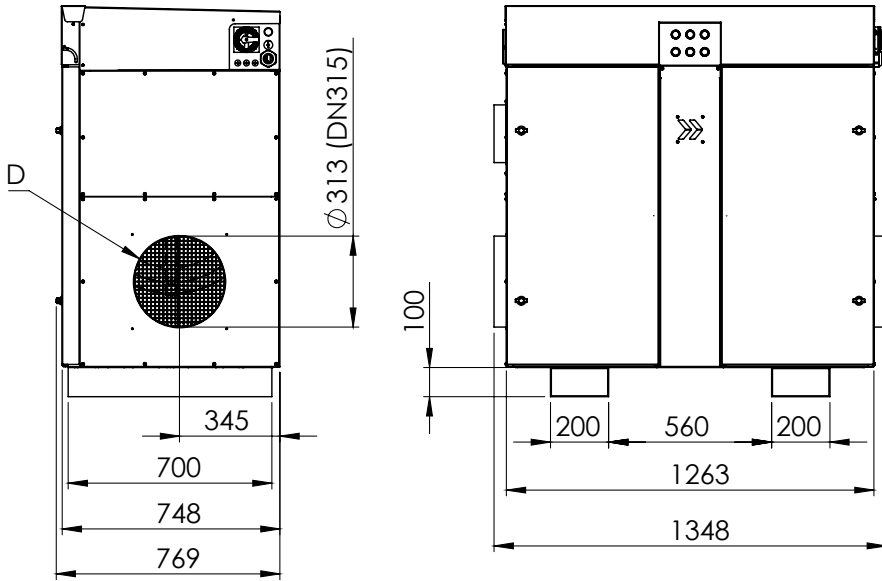

- A) Process air inlet
- B) Regen. air inlet
- C) Wet air outlet
- D) Dry air outlet

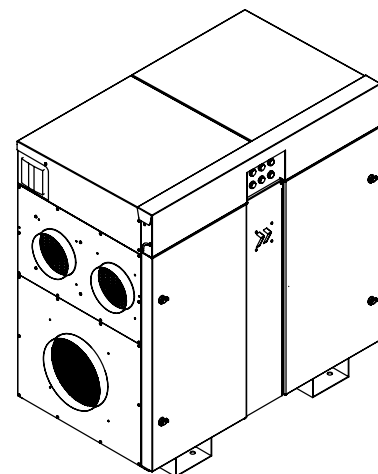
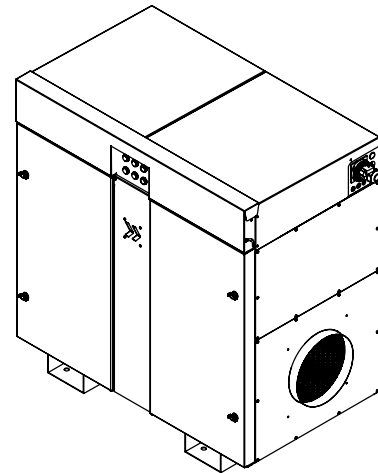
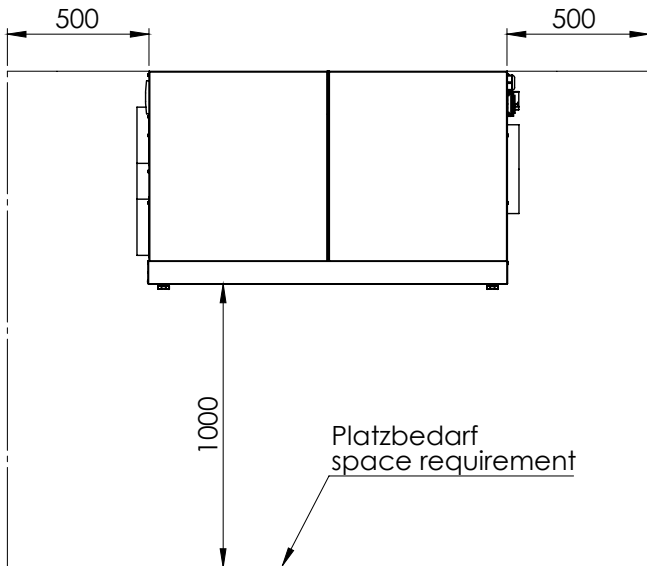

Copying of this Document, and giving it to others and the use or communication of the contents there of, are forbidden without express authority. Offenders are liable to the payment of damages.

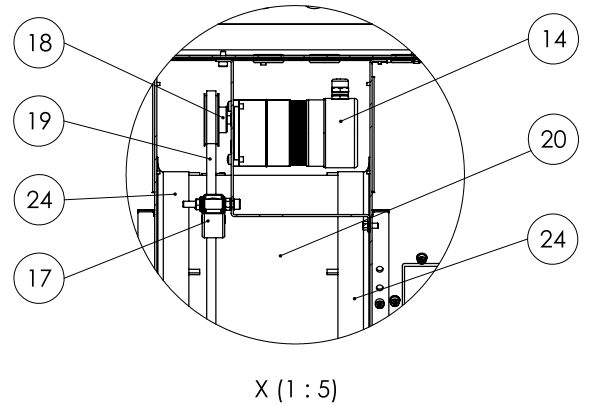
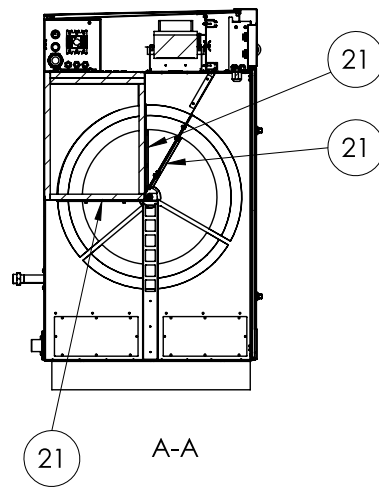
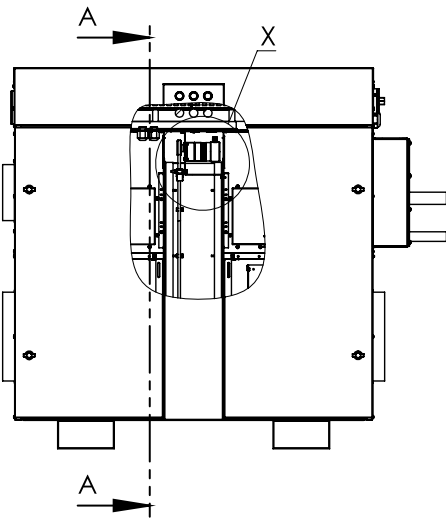
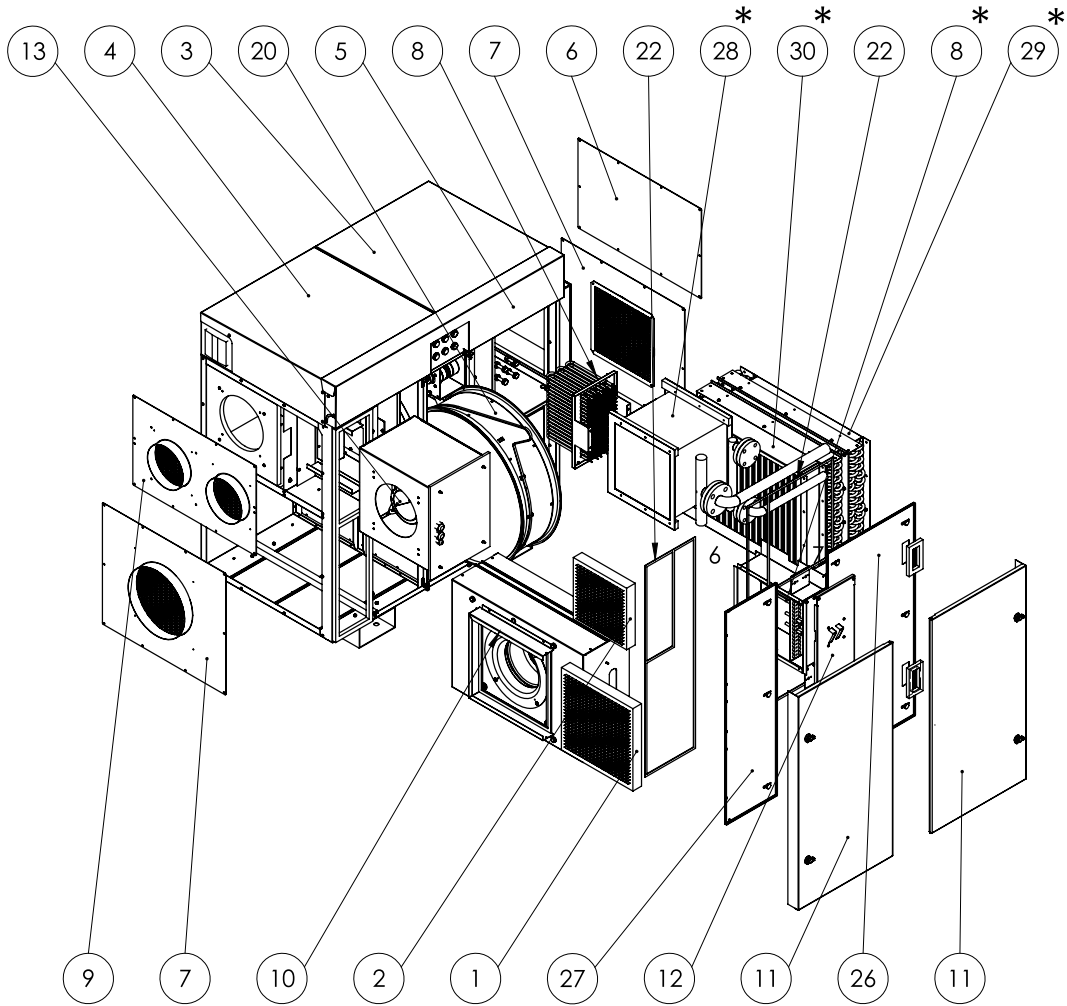

Copying of this Document, and giving it to others and the use or communication of the contents there of, are forbidden without express authority. Offenders are liable to the payment of damages.

| Spare Parts | | TR570 | TR830 | TR1100 |
|-------------------------------|------|------------|------------|------------|
| Description | Item | Trotec no. | Trotec no. | Trotec no. |
| Filter G4 (dry air) | 1 | 7160000428 | 7160000428 | 7160000428 |
| Filter F7 | 1 | 7160000429 | 7160000429 | 7160000429 |
| Filter G4 (regen.-air) | 2 | 7160000404 | 7160000404 | 7160000404 |
| Filter F7 | 2 | 7160000409 | 7160000409 | 7160000409 |
| cover 1 (cabinet) | 3 | P10004261P | 10004261P | 10004261 |
| cover 2 (cabinet) | 4 | P10004260P | 10004260P | 10004260 |
| hinged cover (cabinet) | 5 | P10004142P | 10004142P | 10004142 |
| dummy cover (outside) | 6 | P10004120P | 10004120P | 10004120 |
| cover (process-air) | 7 | B1277B | 1277B | 1277 |
| heating element 450W | 8 | P10003838P | 10003838- | -- |
| heating element 650W | 8 | P10003839P | 10003839P | 10003839 |
| cover (regeneration-air) | 9 | B1276B | 1276B | 1276 |
| fan (process-air) | 10 | P10001383P | 10001383P | 10003451 |
| door | 11 | P10004122P | 10004122P | 10004122 |
| frontpanel | 12 | P10004123P | 10004123P | 10004123 |
| fan (regeneration-air) | 13 | P10003346P | 10003346P | 10003414 |
| geared motor | 14 | P10003432P | 10003432P | 10003432 |
| belt tensioner | 17 | B1204B | 1204B | 1204 |
| synchronizing pulley | 18 | P10000279P | 10000279P | 10000279 |
| synchronizing belt | 19 | P10003902P | 10003904P | 10005016 |
| dessiccant wheel | 20 | P10003407P | 10003408P | 10003409 |
| sealing tape (segment gasket) | 21 | P10003550P | 10003550P | 10003550 |
| gasket (doors) | 22 | P10005020P | 10005020P | 10005020 |
| sealing tape (rotor sealing) | 24 | P10003636P | 10003636P | 10003636 |
| gasket (covers) | 25 | P10005020P | 10005020P | 10005020 |
| sealing cover big (door) | 26 | P10004130P | 10004130P | 10004130 |
| sealing cover small (door) | 27 | P10004129P | 10004129P | 10004129 |
| heat exchanger air-steam | 28 | P10006842P | 10006842P | 10006842 |

| Spare Parts | | TR570 | TR830 | TR1100 |
|--------------------------|------------------|------------|------------|------------|
| Description | Item | Trotec no. | Trotec no. | Trotec no. |
| heat exchanger air-water | 29 | P10006861P | 10006861P | 10006861 |
| mist eliminator | 30 | P10006863P | 10006863P | 10006863 |
| | | | | |
| emergency-mainswitch | 3Q1 | P10004065P | 10004065P | 10003918 |
| SSR-relay | 6Vx | P10001431P | 10001431P | 10001431 |
| heat sink with fan | 6Mx | P10001433P | 10001433P | 10001433 |
| load relay | 6Qx | P10001238P | 10001238P | 10001238 |
| coupling relay | xKx | P10006608P | 10006608P | 10006608 |
| circuit breaker | 4F2+5 | P10003533P | 10003533P | 10003533 |
| circuit breaker | 4F3 | P10004215P | 10004215- | -- |
| circuit breaker | 6F1 6F2 | P10004056P | 10004056P | 10004056 |
| circuit breaker | 8F1 10F1 | P10004057P | 10004057P | 10004057 |
| circuit breaker | 4F1 | P10004058P | 10004058P | 10004058 |
| switching power-supply | 4T1 5T1 | P10003682P | 10003682- | -- |
| switching power-supply | 4T1 | ---- | -- | P10001313 |
| dP-pressure-switch | 17B1+2 | P10001544P | 10001544P | 10001544 |
| dP-pressure-switch | 15B3 | P10001803P | 10001803P | 10001803 |
| STB temperature limiter | 15B1+2 | P10004002P | 10004002P | 10004002 |
| Potentiometer 10K | 8R4 10R4 | P10001751P | 10001751P | 10001751 |
| Potentiometer PWM | 16R2 | P10000291P | 10000291- | -- |
| thermostat | 16B1+2 | P10003442P | 10003442P | 10003442 |
| turning knob thermostat | 16B1+2 | P10003579P | 10003579P | 10003579 |
| timing relay | 15K1 | P10000194P | 10000194P | 10000194 |
| thermo-switch | 16B4 | P10004019P | 10004019P | 10004019 |
| plc Millenium TTR | 21A1 | P10003949P | 10003949P | 10003949 |
| Pt100 transducer | 22B1 22B2 | P10003951P | 10003951P | 10003951 |
| Pt100 temperature sensor | 22B1.1 22B2.1 | P10003950P | 10003950P | 10003950 |
| proximity switch | 22B6 | P10002283P | 10002283P | 10002283 |

Projektdaten:

Baureihe: GEH 6520
 Zeichnungsnummer:6520_Standard_01
 Modell: TR570/830/1100
 Bearbeiter: U. Samplatzki
 geprüft: S. Schüll
 Datum: 10.12.2018

Vorschrift: VDE
 Einspeisung: 3 x 380-480V 50/60Hz + PE
 Steuerspannung: 24V DC
 TR 1100 Nennleistung: 28,8 kW
 TR 1100 Stromaufnahme: I_{NENN} 41,6A (@ 400V)
 TR 830 Nennleistung: 21,5 kW
 TR 830 Stromaufnahme: I_{NENN} 31,0A (@ 400V)
 TR 570 Nennleistung: 15,0 kW
 TR 570 Stromaufnahme: I_{NENN} 21,7A (@ 400V)

| | | | | | | |
|---|-------|---------------|-----------------|-----------------|--------------|-----------------|
|  | Dat. | 11.12.2018 | a_Deckblatt_TTR | TR 570_830_1100 | Zeichn. Nr.: | EEA-100-0097-02 |
| | Gest. | U. Samplatzki | | | Ausführung: | |
| | Gepr. | S. Schüll | | | | a_Deckblatt_TTR |
| | Rev. | 1218 | | | | Blatt 1 |

Copying of this Document, and giving it to others and the use or communication of the contents there of, are forbidden without express authority. Offenders are liable to the payment of damages.

| | | | |
|----------------------------------|---------------------------------------|-----------------------------|--------------|
| operating voltage : | 400V AC / PE / 50Hz | control voltage : | 24V DC |
| power : | device-specific | lamp voltage : | 24V DC |
| fuse : | power-specific | PLC-voltage : | 24V DC |
| | | | |
| cabinet details implementation : | protection class : cabinet integrated | wire color codes main power | |
| single field - size : | H , W , D mm | wire type : | flexible |
| cabinet socket : | type-specific | L1 phase : | black |
| full field - size : | | L2 phase : | black |
| color outside / inside : | - | L3 phase : | black |
| mounting plate color : | - | neutral conductor N : | blue |
| cable entries : | from right ! | protective conductor PE : | green/yellow |
| | | output DC <= 24V | red/white |

Legend

cross-reference naming

At the right side of contact images for contactors, relays or time-relays, a numerical reference is shown. This reference specifies the page number and path where the corresponding contact is located. For the naming of potentials, the same reference type is used to indicate the next location of the same potential. The schematic representation for cross-reference is printed as: "/" "page number" "." "path"

device naming : example 21 K 1 .1

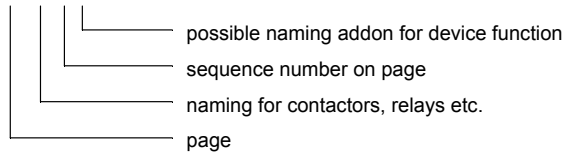

naming for contactors "K" etc. :

It distinguishes between contactors, relays "K", main switch, motor protection switch and power relays "Q", lights "P", pressure switch, thermostats and sensors "B", fuses "F", transducers "U", motors "M", actuator "Y" and regulators "N", DDC devices "A" etc.

additional device naming for function ".1" etc.:

to differentiate between the device functions, a sequence number will be appended separated by a dot.

Attention!!

before connect power and operating the machine, tightening all (terminal, contactors, auxiliary contactors etc.) especially all power connections must be tightened.



| | |
|-------|---------------|
| Dat. | 06.09.2018 |
| Gez. | U. Samplatzki |
| Gepr. | |
| Rev. | 0918 |

b_Legende_TTR

TR 570_830_1100

Zeichn. Nr.: EEA-100-0211_01

Ausführung:

b_Legende_TTR
Blatt 2

Copying of this Document, and giving it to others and the use or communication of the contents there of, are forbidden without express authority. Offenders are liable to the payment of damages.

TR 570 / TR 830 / TR 1100

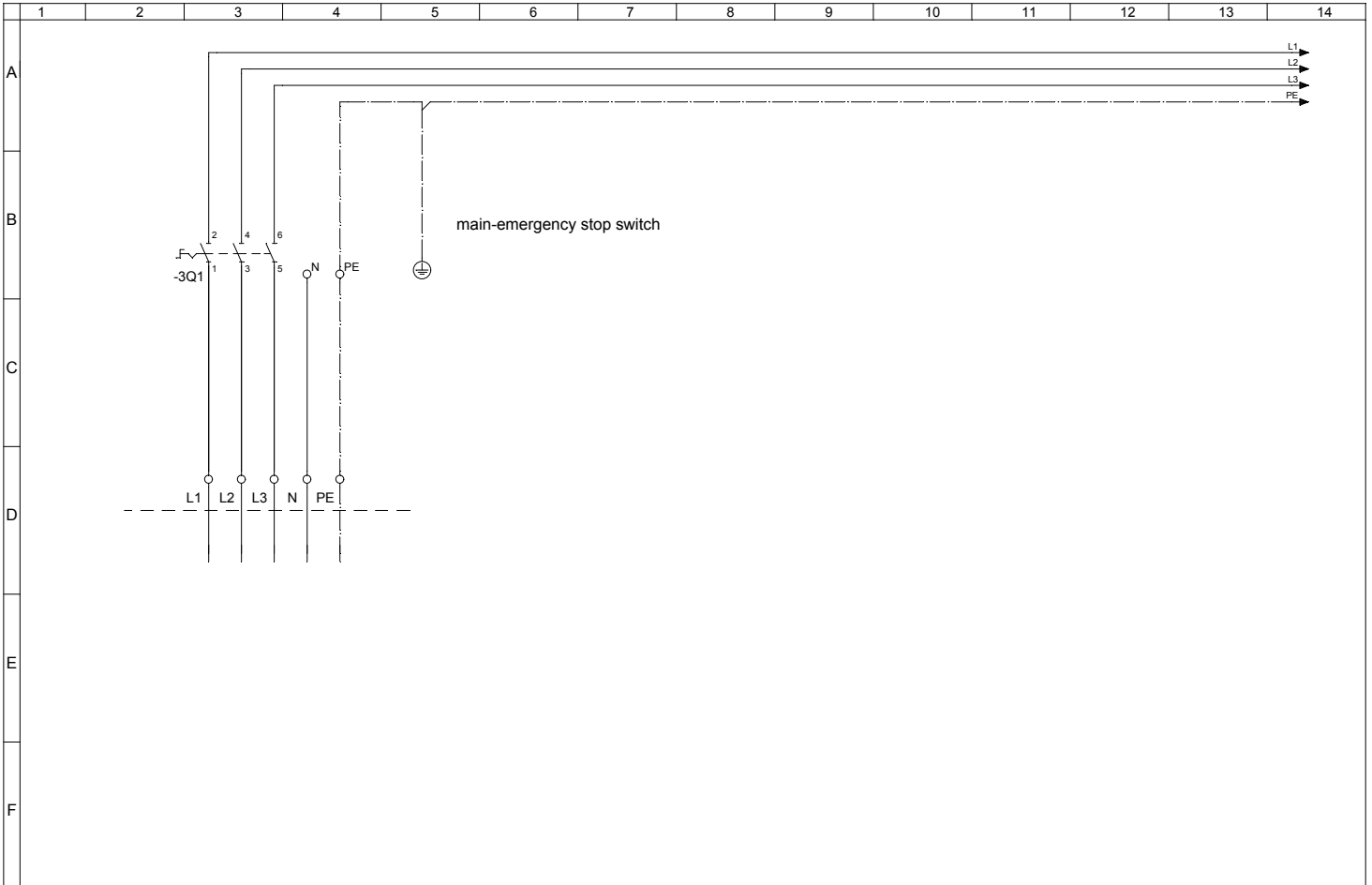

| | | |
|-------|--------------|-------------------|
| Dat. | 06.09.2018 | c_Einspeisung_TTR |
| Gez. | U.Samplatzki | |
| Gepr. | | |
| Rev. | 0918 | |

TR 570_830_1100

Zeichn. Nr.: EEA-100-0067-02

Ausführung:

| |
|-------------------|
| c_Einspeisung_TTR |
| Blatt 3 |

Copying of this Document, and giving it to others and the use or communication of the contents there of, are forbidden without express authority. Offenders are liable to the payment of damages.



TR 570 / TR 830 / TR 1100

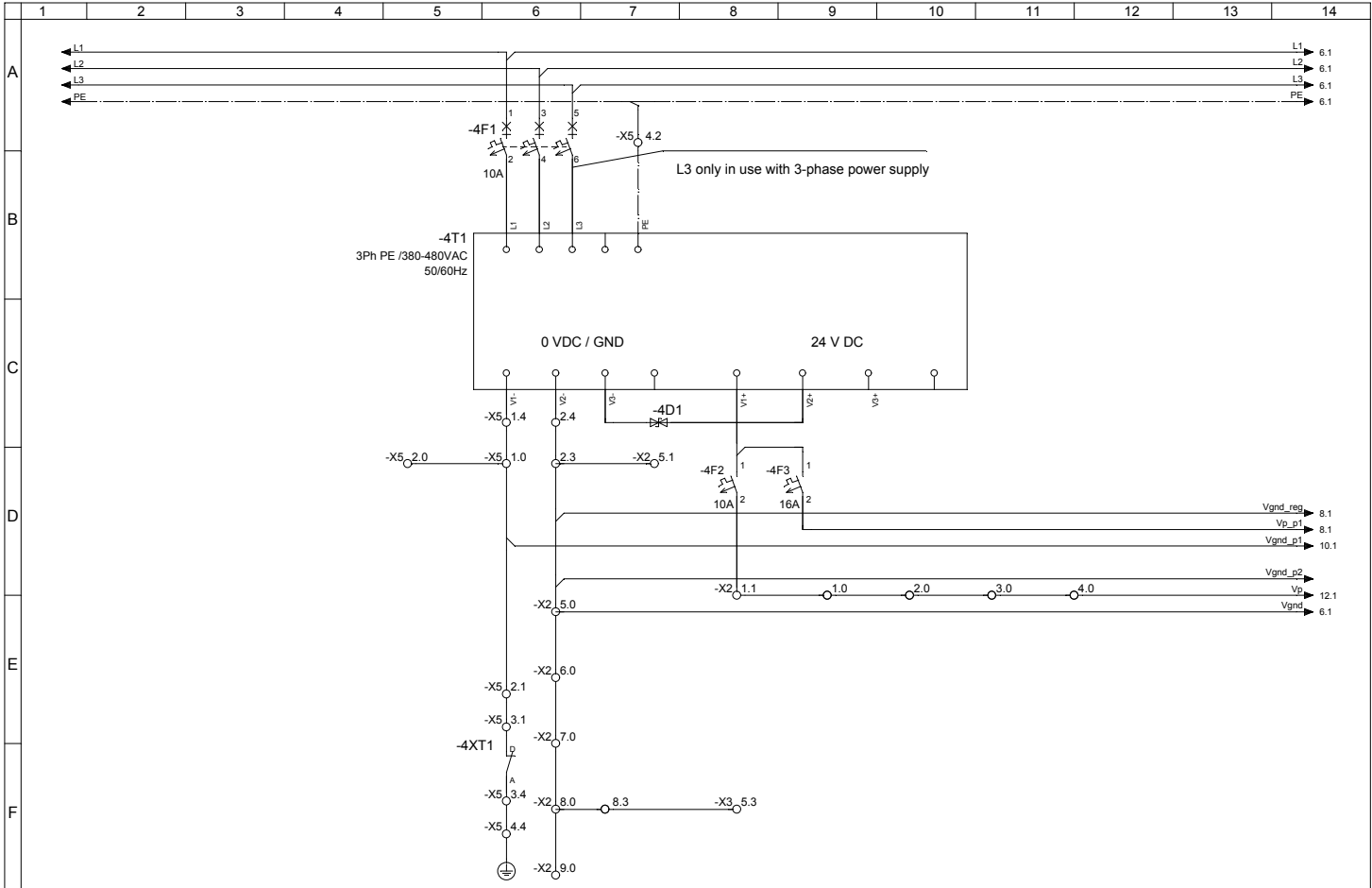

| | | |
|-------|---------------|----------------------|
| Dat. | 10.12.2018 | d_Steuerspannung_TTR |
| Gez. | U. Samplatzki | |
| Gepr. | S. Schüll | |
| Rev. | 1218 | |

TR 570_830_1100

| | |
|--------------|-----------------|
| Zeichn. Nr.: | EEA-100-0215-02 |
| Ausführung: | |

| |
|----------------------|
| d_Steuerspannung_TTR |
| Blatt 4 |

Copying of this Document, and giving it to others and the use or communication of the contents there of, are forbidden without express authority. Offenders are liable to the payment of damages.



TR 570 / TR 830 / TR 1100

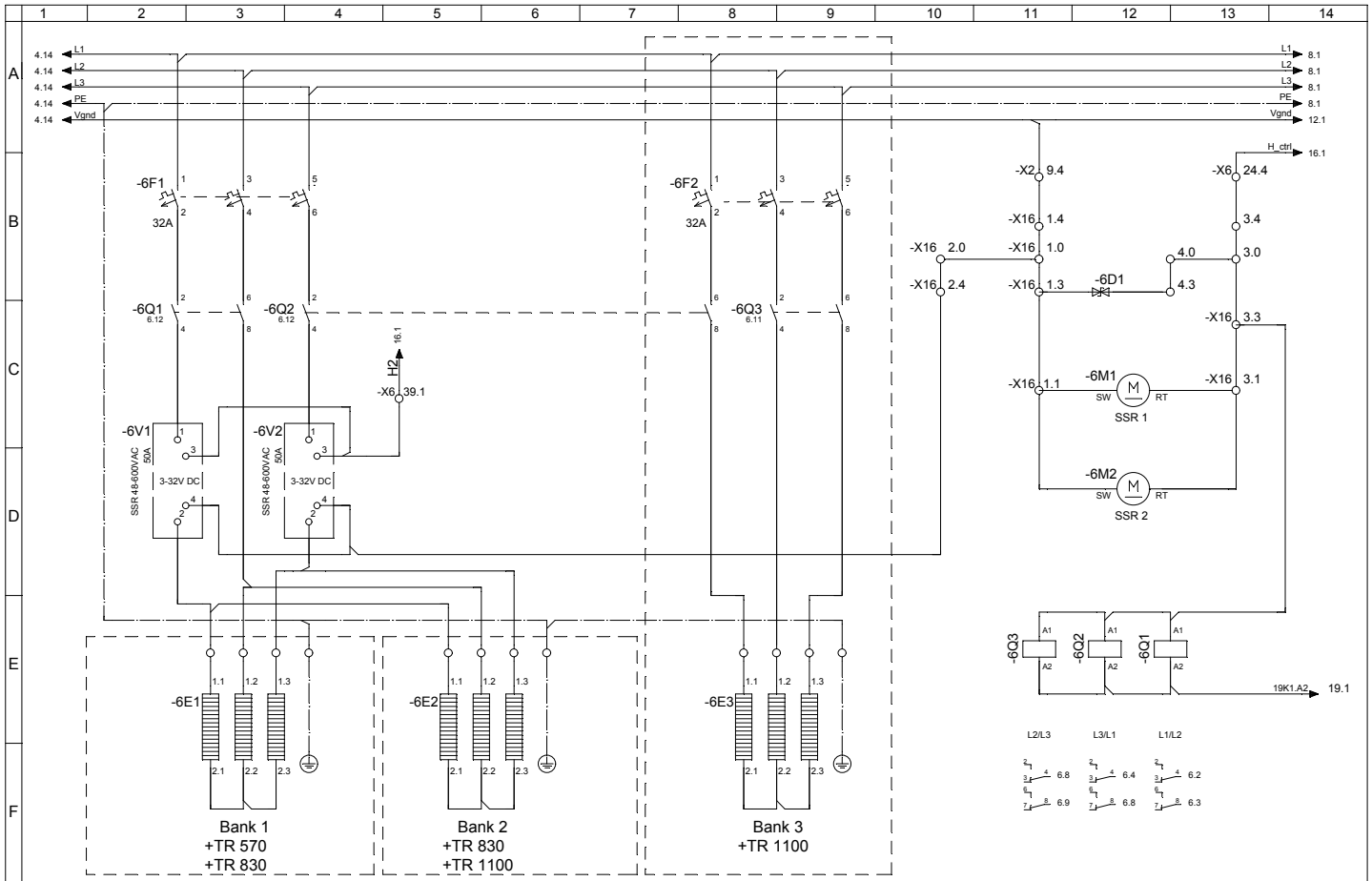

| | | |
|-------|---------------|--------------------------|
| Dat. | 10.12.2018 | f_Reg_Hzg_1_TTR2000_3700 |
| Gez. | U. Samplatzki | |
| Gepr. | S. Schüll | |
| Rev. | 1218 | |

TR 570_830_1100

Zeichn. Nr.: EEA-100-0072-02

Ausführung:

| |
|--------------------------|
| f_Reg_Hzg_1_TTR2000_3700 |
| Blatt 6 |

Copying of this Document, and giving it to others and the use or communication of the contents thereof, are forbidden without express authority. Offenders are liable to the payment of damages.



TR 570 / TR 830 / TR 1100

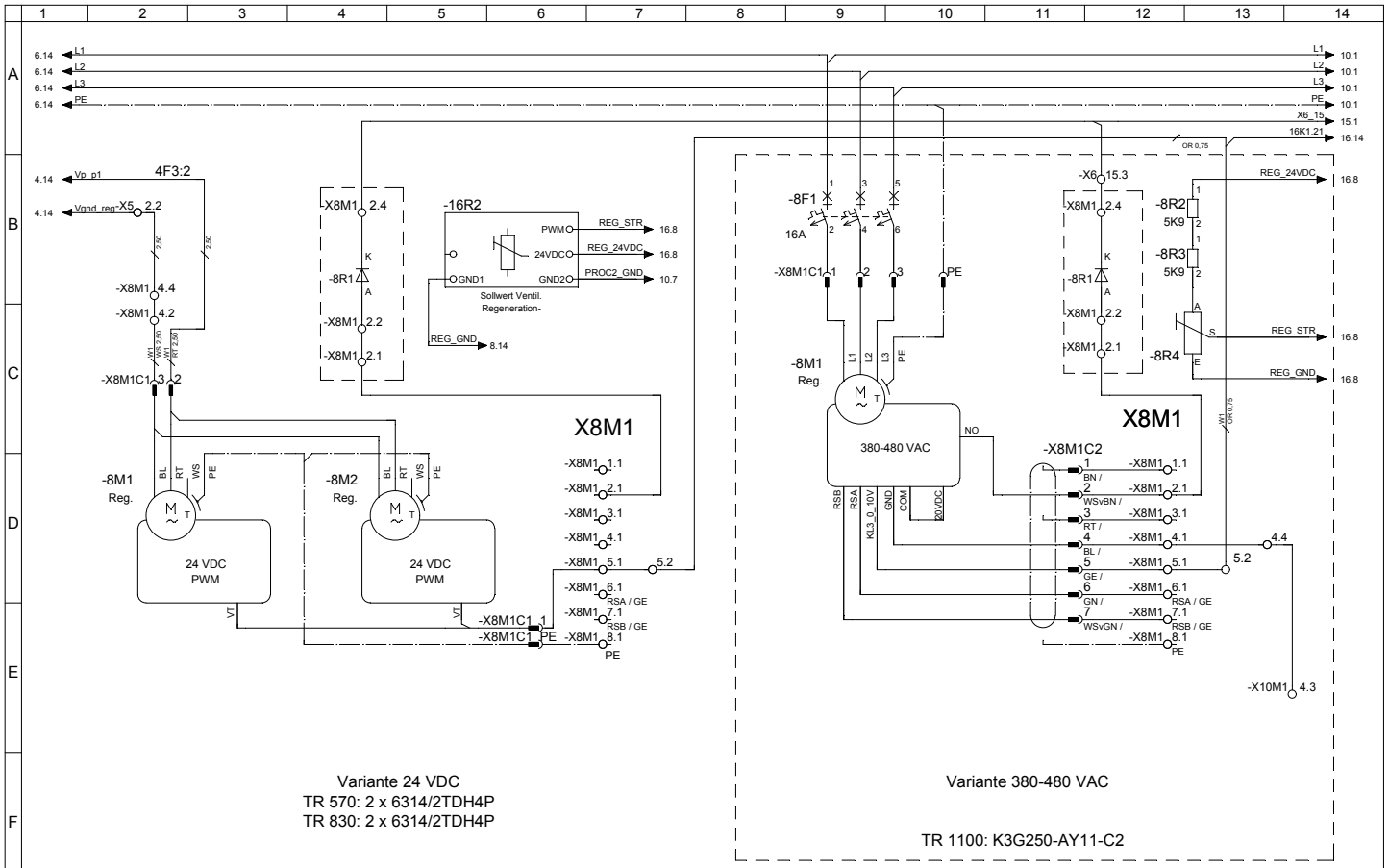

| | | |
|-------|---------------|-------------------------|
| Dat. | 10.12.2018 | h_Reg_Luft_TTR2000_3700 |
| Gez. | U. Samplatzki | |
| Gepr. | S. Schöll | |
| Rev. | 1218 | |

TR 570_830_1100

| | |
|--------------|------------------------------------|
| Zeichn. Nr.: | EEA-100-0080-02 |
| Ausführung: | h_Reg_Luft_TTR2000_3700 Blatt 8 |

Copying of this Document, and giving it to others and the use or communication of the contents there of, are forbidden without express authority. Offenders are liable to the payment of damages.



TR 570 / TR 830 / TR 1100

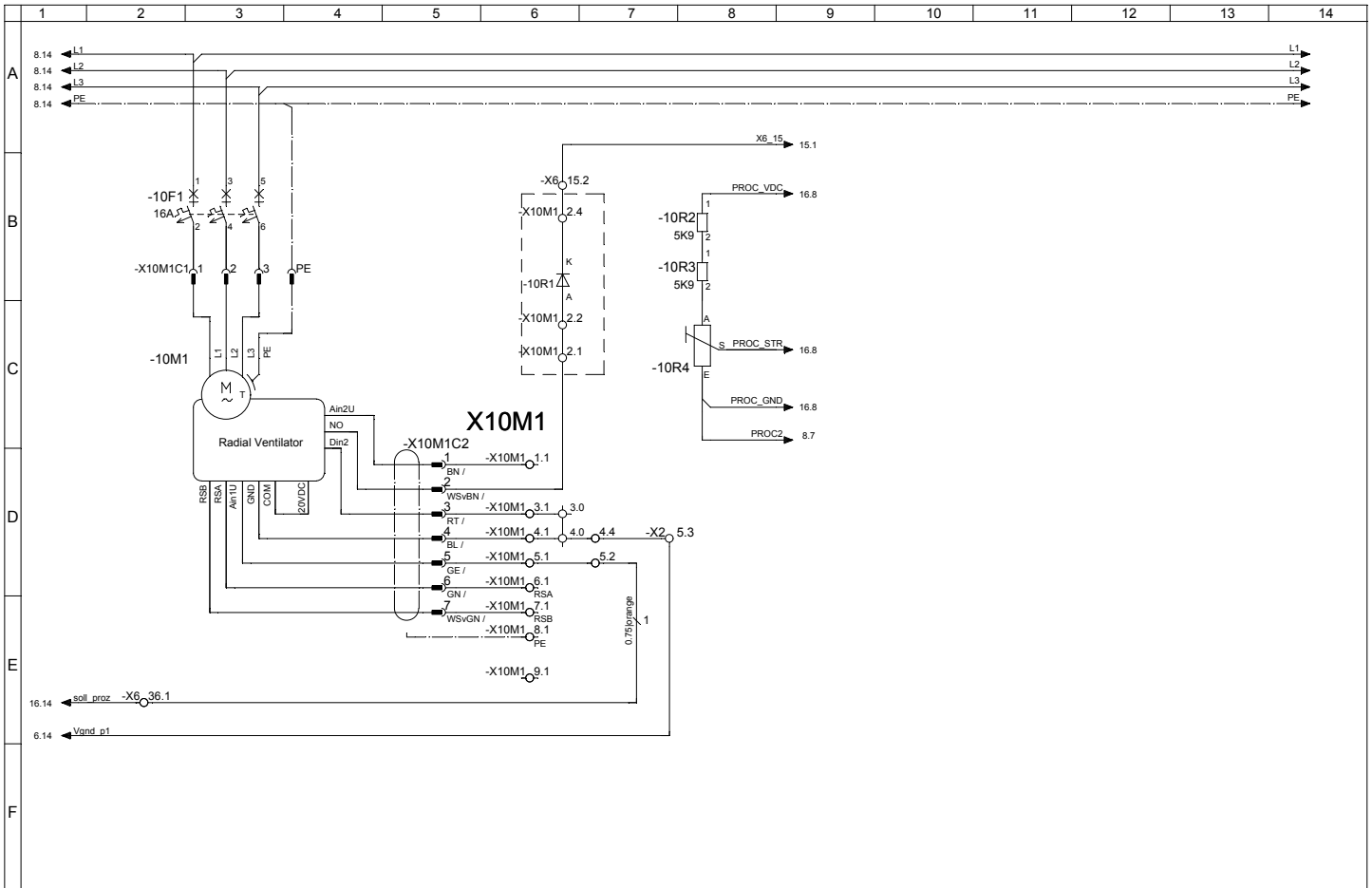

| | | |
|-------|---------------|--------------------------|
| Dat. | 10.12.2018 | I_Proz_Luft_TTR2000_3700 |
| Gez. | U. Samplatzki | |
| Gepr. | S. Schüll | |
| Rev. | 1218 | |

TR 570_830_1100

| | |
|--------------|--------------------------------------|
| Zeichn. Nr.: | EEA-100-0076-02 |
| Ausführung: | i_Proz_Luft_TTR2000_3700 Blatt 10 |

Copying of this Document, and giving it to others and the use or communication of the contents there of, are forbidden without express authority. Offenders are liable to the payment of damages.



TR 570 / TR 830 / TR 1100

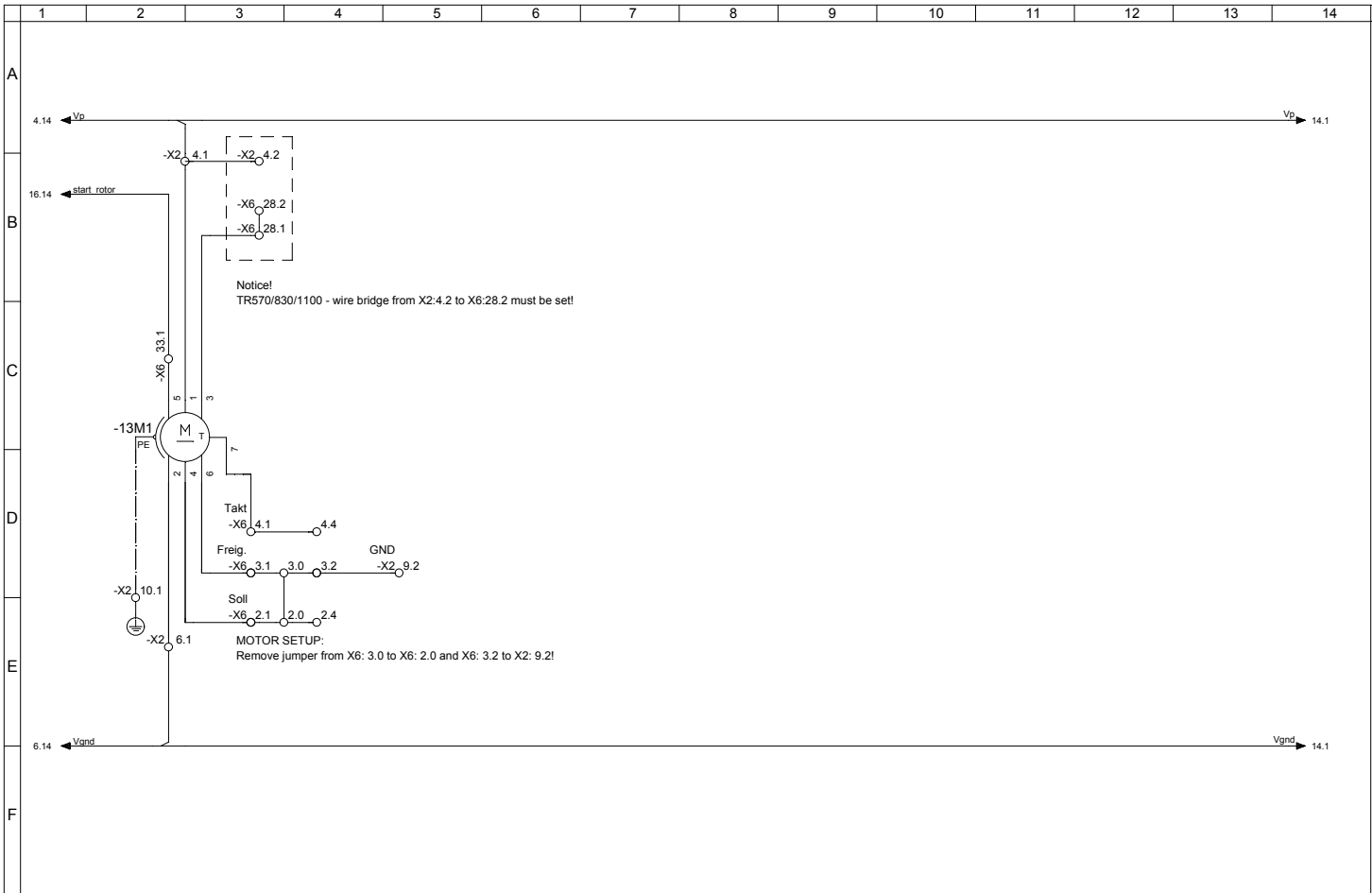

| | | |
|-------|---------------|--------------------|
| Dat. | 10.12.2018 | j_Rotorantrieb_TTR |
| Gez. | U. Samplatzki | |
| Gepr. | S. Schüll | |
| Rev. | 1218 | |

Steuerung TTR

| | |
|--------------|--------------------------------|
| Zeichn. Nr.: | EEA-100-0082-01 |
| Ausführung: | j_Rotorantrieb_TTR Blatt 13 |

Copying of this Document, and giving it to others and the use or communication of the contents there of, are forbidden without express authority. Offenders are liable to the payment of damages.



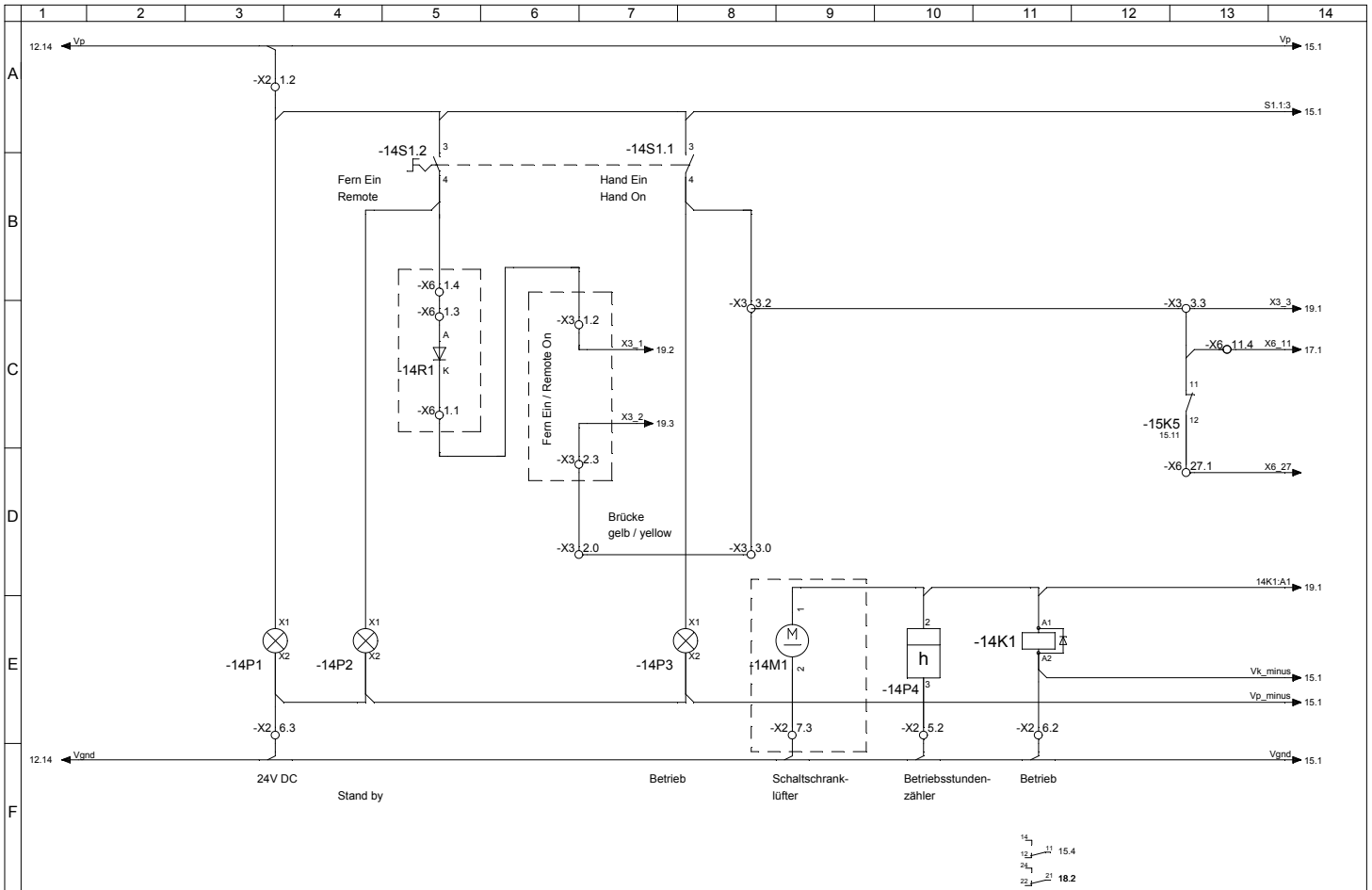

| | | |
|-------|---------------|--------------------|
| Dat. | 10.12.2018 | k_Steuerung_TTR_14 |
| Gez. | U. Samplatzki | |
| Gepr. | S. Schüll | |
| Rev. | 1218 | |

Steuerung TTR

| | | |
|--------------|-----------------|--------------------|
| Zeichn. Nr.: | EEA-100-0156-03 | |
| Ausführung: | | k Steuerung_TTR_14 |
| | | Blatt 14 |

Copying of this Document, and giving it to others and the use or communication of the contents there of, are forbidden without express authority. Offenders are liable to the payment of damages.

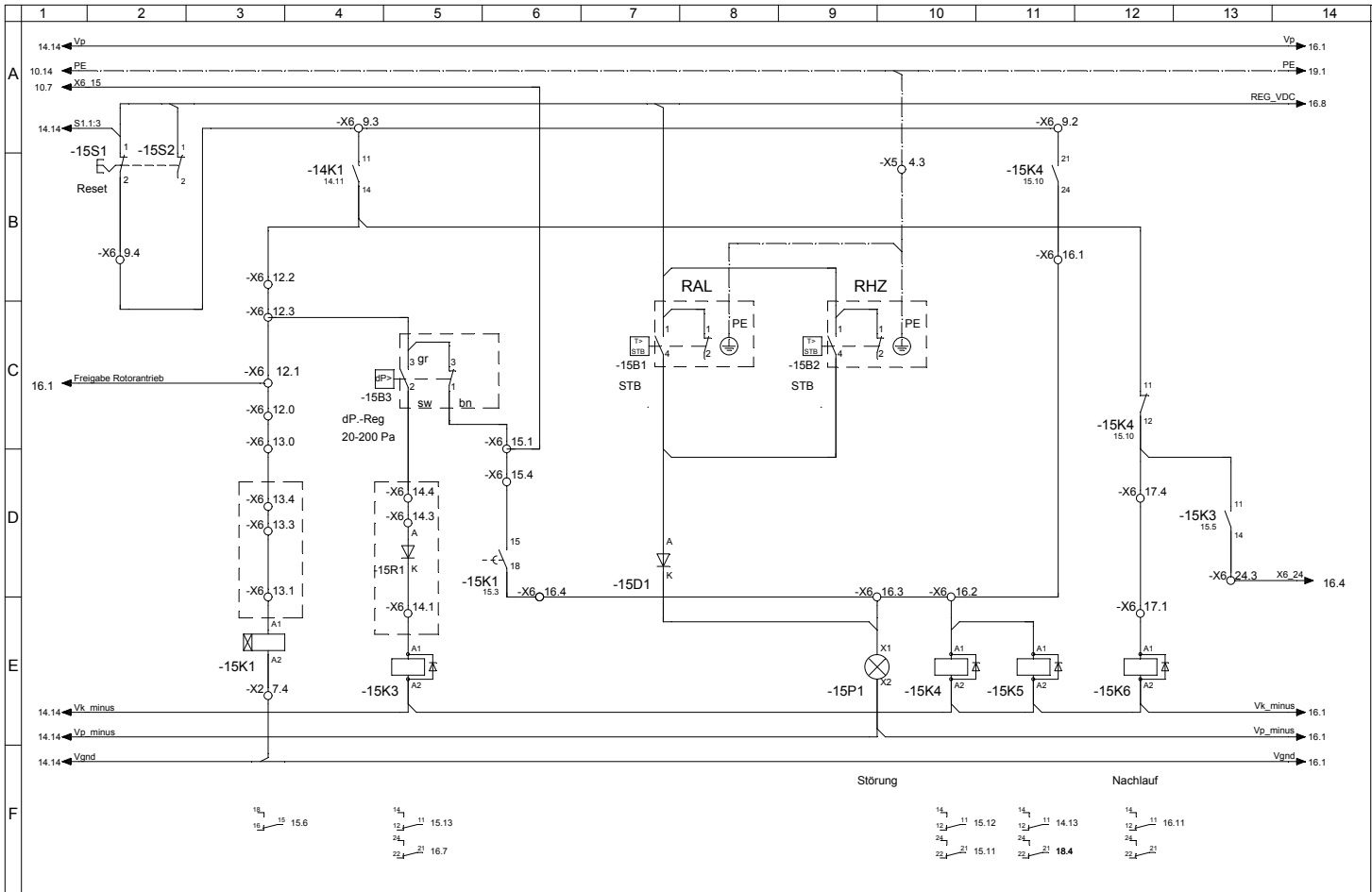

| | | |
|-------|---------------|--------------------|
| Dat. | 10.12.2018 | k_Steuerung_TTR_15 |
| Gez. | U. Samplatzki | |
| Gepr. | S. Schüll | |
| Rev. | 1218 | |

Steuerung TTR

| | |
|--------------|--------------------|
| Zeichn. Nr.: | EEA-100-0156-03 |
| Ausführung: | k_Steuerung_TTR_15 |
| | Blatt 15 |

Copying of this Document, and giving it to others and the use or communication of the contents there of, are forbidden without express authority. Offenders are liable to the payment of damages.

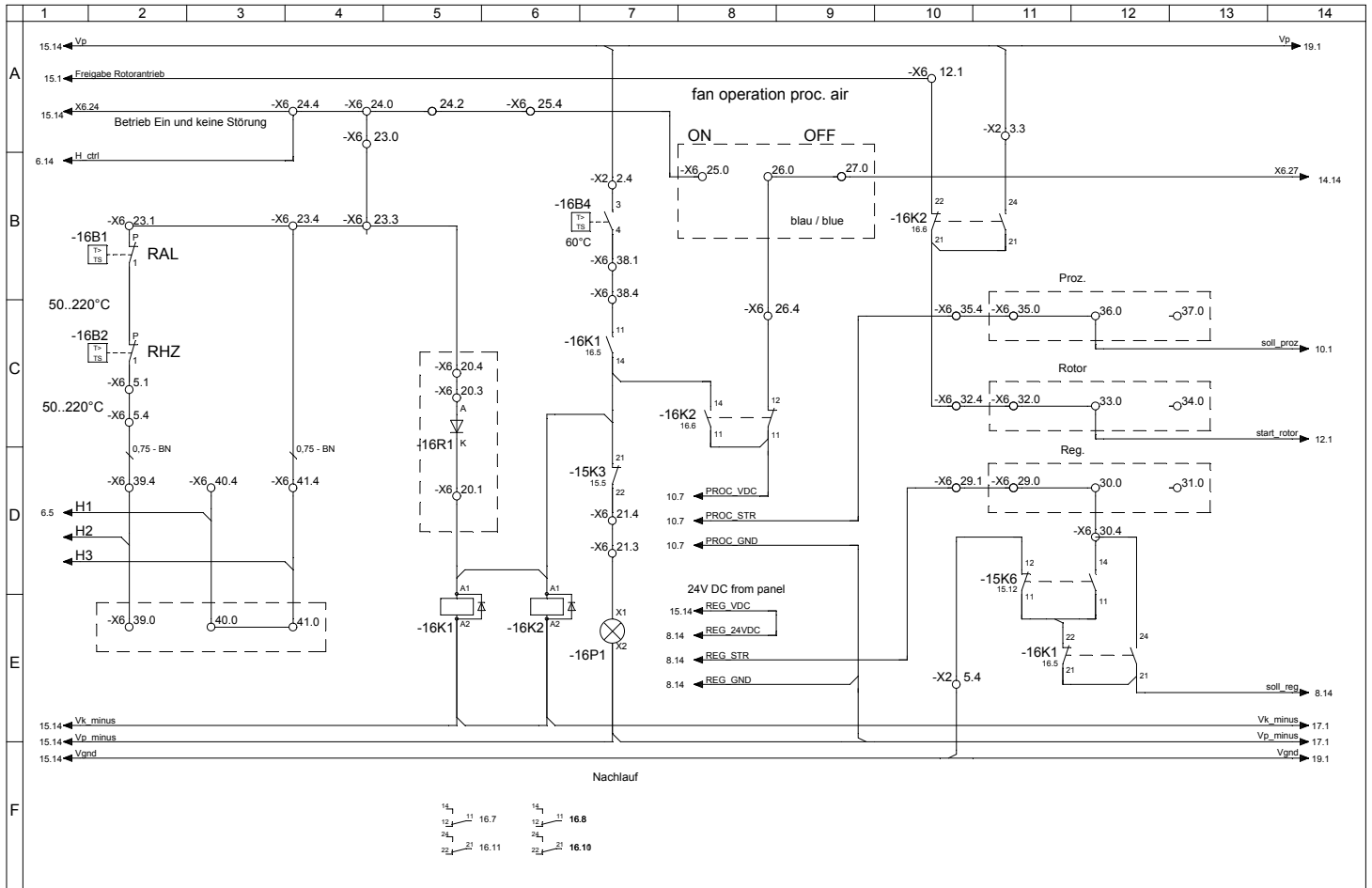

| | | |
|-------|---------------|--------------------|
| Dat. | 10.12.2018 | k_Steuerung_TTR_16 |
| Gez. | U. Samplatzki | |
| Gepr. | S. Schül | |
| Rev. | 1218 | |

Steuerung TTR

| | |
|--------------|--------------------|
| Zeichn. Nr.: | EEA-100-0156-03 |
| Ausführung: | k_Steuerung_TTR_16 |
| | Blatt 16 |

Copying of this Document, and giving it to others and the use or communication of the contents thereof, are forbidden without express authority. Offenders are liable to the payment of damages.

TR 570 / TR 830 / TR 1100

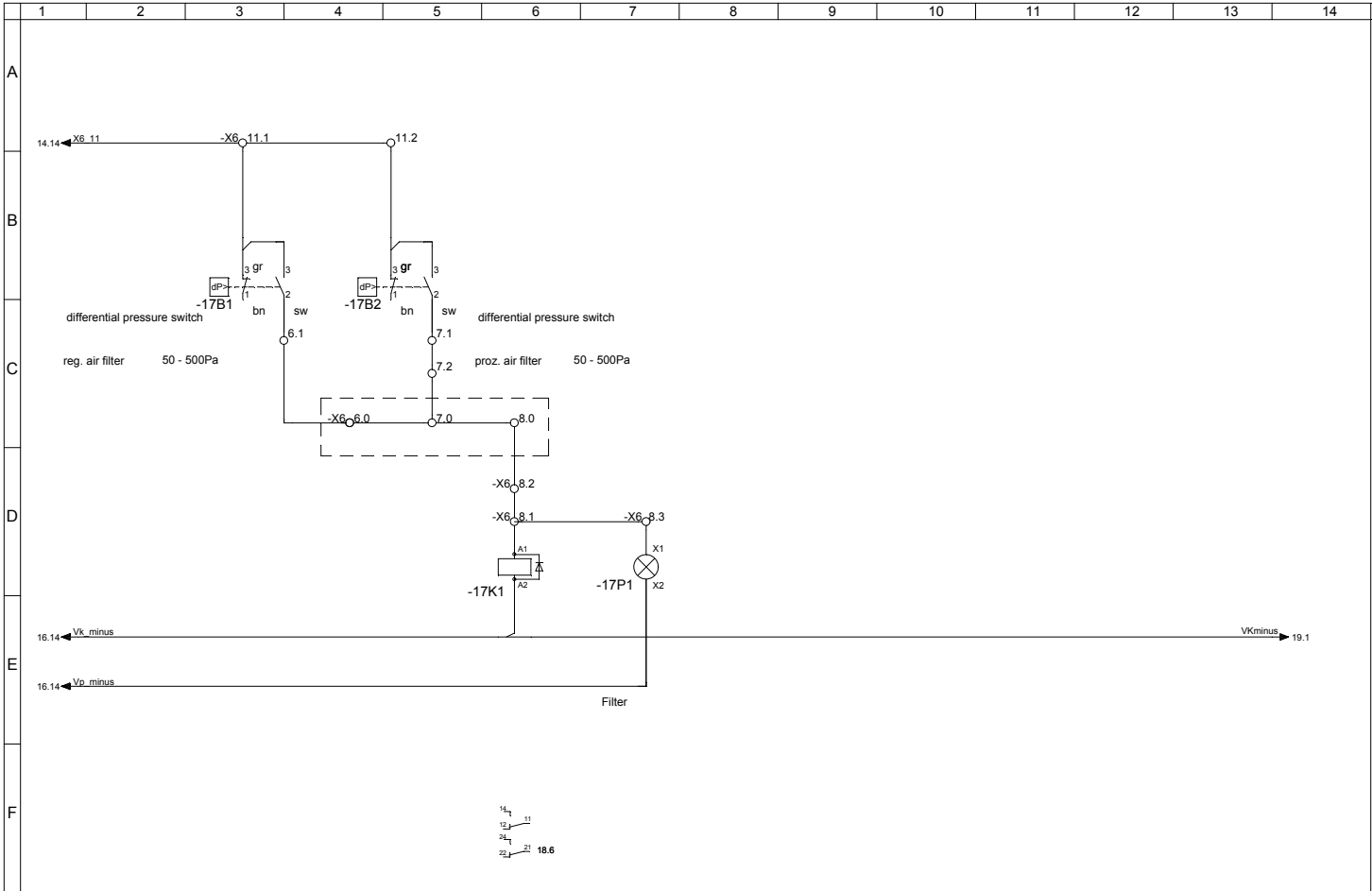

| | | |
|-------|---------------|--------------------|
| Dat. | 10.12.2018 | k_Steuerung_TTR_17 |
| Gez. | U. Samplatzki | |
| Gepr. | S. Schüll | |
| Rev. | 1218 | |

Steuerung TTR

| | |
|--------------|--------------------|
| Zeichn. Nr.: | EEA-100-0156-03 |
| Ausführung: | k_Steuerung_TTR_17 |
| | Blatt 17 |

Copying of this Document, and giving it to others and the use or communication of the contents there of, are forbidden without express authority. Offenders are liable to the payment of damages.



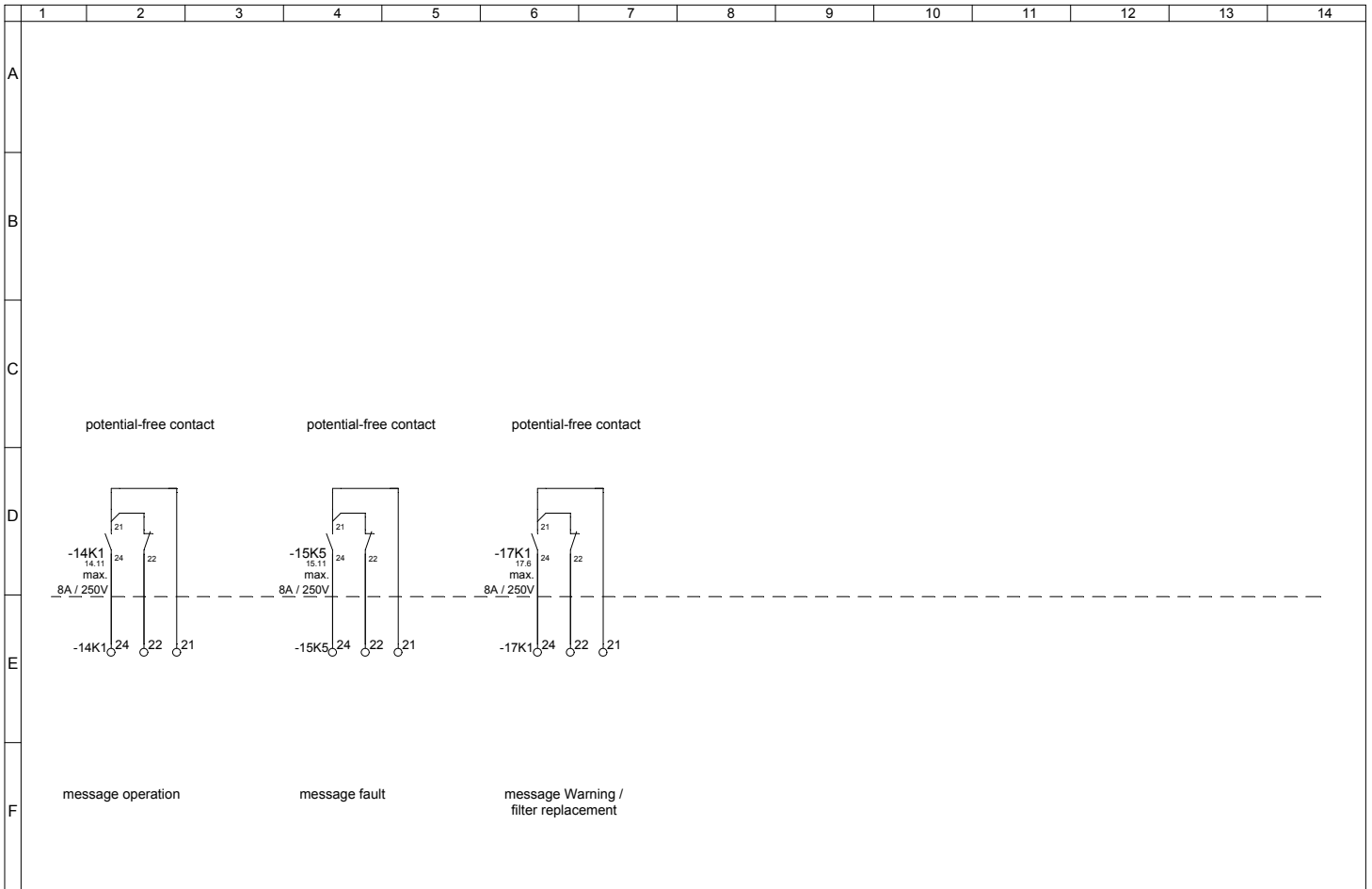

| | | |
|-------|---------------|--------------------|
| Dat. | 10.12.2018 | k_Steuerung_TTR_18 |
| Gez. | U. Samplatzki | |
| Gepr. | S. Schüll | |
| Rev. | 1218 | |

Steuerung TTR

| | |
|--------------|--------------------------------|
| Zeichn. Nr.: | EEA-100-0156-03 |
| Ausführung: | k Steuerung_TTR_18 Blatt 18 |

Copying of this Document, and giving it to others and the use or communication of the contents there of, are forbidden without express authority. Offenders are liable to the payment of damages.

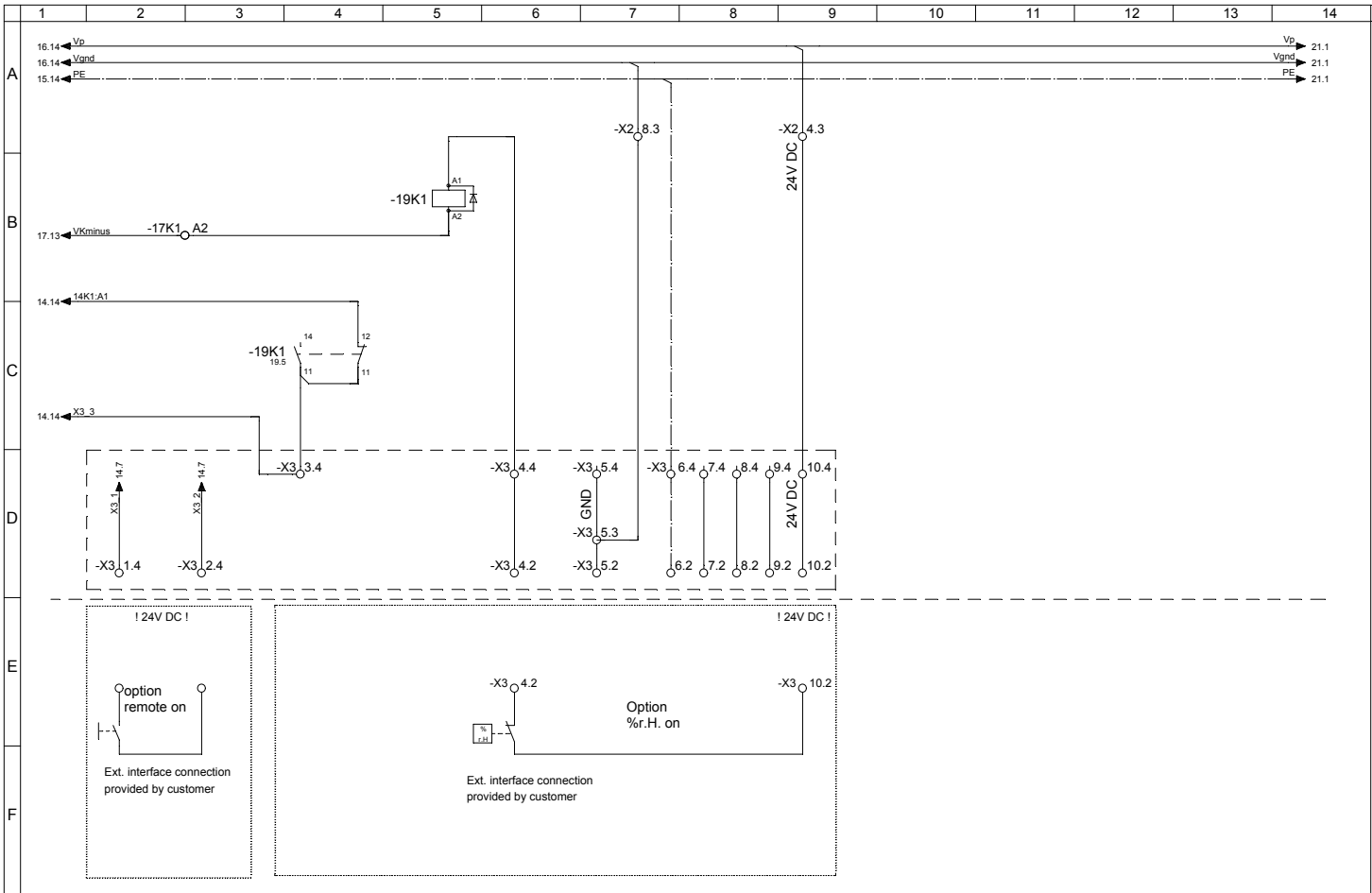

| | | |
|-------|---------------|--------------------|
| Dat. | 10.12.2018 | k_Steuerung_TTR_19 |
| Gez. | U. Samplatzki | |
| Gepr. | S. Schüll | |
| Rev. | 1218 | |

Steuerung TTR

| | |
|--------------|--------------------|
| Zeichn. Nr.: | EEA-100-0156-03 |
| Ausführung: | k_Steuerung_TTR_19 |
| | Blatt 19 |

Copying of this Document, and giving it to others and the use or communication of the contents there of, are forbidden without express authority. Offenders are liable to the payment of damages.

| EN | FR |
|---|--|
| dimensions (mm) | Dimensions (mm) |
| activation | déclenchement |
| ports | Branchement |
| connected load | Puissance a prévoir |
| on-delayed | Retardement |
| work area | Plage de travail |
| interpretation | Conception |
| damp air outlet | Sortie d'air humide |
| dry air outlet | Sortie d'air sec |
| model series | Numéro de série |
| limiter | Limiteur |
| With 0-10V control signal a reconfiguration of the MU input is necessary. | Avec un signal de commande 0-10V, une reconfiguration de l'entrée MU est nécessaire. |
| For hygostat use blue bridge ... remove | Avec l'hygostat, enlever le shunt bleu... |
| ready | Prêt |
| operation | Marche |
| operation on | Fonctionnement Marche |
| Electrical operating range | Plage de fonctionnement électrique |
| operating range airflows | Plage de fonctionnement Débits d'air |
| operating voltage | Tension de fonctionnement |
| operating hours counter | Compteur d'heures de fonctionnement |
| blue | Bleu |
| brown | Brun |
| bridge | Shunt |
| plug bridge | Connecter le shunt |
| reconnect bridge | Déconnecter le shunt |
| remove bridge from ... to ... and ... to ... | Shunt de .. À .. Et de .. À .. A déconnecter |
| socket | Raccordement |
| steam valve | Soupape de vapeur |
| differential pressure | Différence de pression |
| differential pressure switch | Pressostat |
| diode terminal | Bornier a diodes |
| remove wire | Retirer le fil |
| wire bridge | Fil de shunt |

| EN | FR |
|-------------------------------------|-----------------------------------|
| wire bridge from ... set to ... set | Fil de shunt de .. A .. À insérer |
| rotation control | Contrôleur de rotation |
| rotary potentiometers | potentiomètres rotatifs |
| rotary potentiometers | potentiomètres rotatifs |
| direction of rotation | sens de rotation |
| speed sensor | capteur de vitesse |
| pressure control | contrôle de pression |
| pressure sensor | détecteur de pression |
| on | On |
| slide-in module | module enfichable |
| feed | Alimentation |
| Process air inlet | Entrée d'air de process |
| Regeneration air inlet | Entrée d'air de régénération |
| recommended protection | protection recommandée |
| dehumidification performance | performance de déshumidification |
| spare parts | pièces de rechange |
| spare parts list | liste des pièces détachées |
| Ext. connection | Raccordement ext. |
| External | Externe |
| Far On | Commande externe |
| remote control | Commande à distance |
| humidity control | contrôle de l'humidité |
| filters | filtres |
| Filter Fan | Filtres à air |
| filter monitoring | surveillance de filtre |
| filter change | changement de filtre |
| blowing free | Soufflage libre |
| release | déblocage |
| probe | Capteur |
| yellow | Jaune |
| weight | Poids |
| green | Vert |
| manual on | Hand On |
| Main/Emergency-Off Switch | Interrupteur arrêt d'urgence |
| heater | Chauffage |

| EN | FR |
|---|---|
| rear | Derrière |
| reference | Nota |
| hygrostat | Hygrostat |
| hygrostat on | Hygrostat On |
| at 3 ft distance, arithmetic mean, max. fan speed | A une distance de 1m, vitesse max du ventilateur, avec une moyenne arithmétique |
| induction switch | Interrupteur a inudction |
| actual value | valeur réelle |
| jumpers | Cavalier |
| condensate drip tray | bac de récupération des condensats |
| contact field | champ de contact |
| cooling unit | unité de réfrigération |
| cooling | Refroidissement |
| Customer side | Côté client |
| lamp | lampe |
| power | Capacité |
| power relay | relais de puissance |
| circuit breaker | disjoncteur |
| purple | violet |
| links | Gauche |
| air | air |
| air-steam | Vapeur d'air |
| fan | ventilateur |
| air filter replacement | remplacement du filtre à air |
| air duct | conduit d'aération |
| air duct connection | Raccordement a la conduite d'air |
| air-water | air-eau |
| dimension sketch | Schéma dimensionnel |
| pilot light | voyant de signalisation |
| signal | Signalisation |
| transducer | Émetteur |
| motor | Moteur |
| after | Après |
| reheater | Chauffage additionnel |
| run-on | Temporisation d'arrêt |

| EN | FR |
|---|---|
| post-temperature | post-chauffage |
| proximity switches | capteurs de proximité |
| nominal power | puissance nominale |
| rated current | courant nominal |
| mains connection | raccordement au secteur |
| power supply | source d'alimentation |
| non-condensing | sans condensation |
| N-disconnect terminal | Borne de déconnexion N |
| only for use with 3-phase power supply unit | uniquement pour utilisation avec bloc d'alimentation triphasé |
| option | Option |
| orange | Orange |
| position | Position |
| potential-free contact | Contact libre de potentiel |
| pressing | Pression d'air |
| process air | Proz. |
| process air | Air de process |
| process external air | Air de process extérieur |
| PT100 sensor | Capteur PT100 |
| PT100 transmitter | Émetteur PT100 |
| right | Droite |
| control thermostat | Thermostat de régulation |
| regulation | Commande |
| control valve | vanne de régulation |
| regeneration Air | Air de régénération |
| relay | Relais |
| reset | Reset |
| red | rouge |
| rotor | rotor |
| rotor rotation control | Contrôle de la rotation du rotor |
| rotor plate | Plaque du rotor |
| rotor drive | Entrainement du rotor |
| sound pressure level | niveau de pression acoustique |
| switching contact | Contact de commande |
| switch cabinet | armoie de commande |

| EN | FR |
|----------------------------|-------------------------------------|
| fuse | Fusible |
| contactor | contacteur |
| protection class electric | Classe de protection électrique |
| protection class enclosure | Classe de protection de l'enveloppe |
| black | Noir |
| sensor technology | Capteurs |
| fuse | Fusible |
| circuit breaker | disjoncteur |
| Signal adjustment | Réglage du signal |
| signal separation | séparation du signal |
| Solid State Relay | Relais statique |
| target value | valeur nominale |
| PLC control module | Module de commande SPS |
| forklift pocket | Prise pour chariot élévateur |
| start | Start |
| socket | Prise |
| plug | Fiche |
| actuating value | valeur de réglage |
| control voltage | tension de commande |
| control | Commande |
| stop | Stop |
| fault | Défaut |
| current consumption | Compteur énergétique |
| circuit diagram | Schéma électrique |
| push button | bouton |
| technical data | Caractéristiques techniques |
| temperature | température |
| temperature Limiter | Limiteur de température |
| temperature control | régulation thermique |
| thermoswitches | Interrupteur thermique |
| thermostat | thermostat |
| transport frame | châssis de transport |
| disconnect terminal | Bornier |
| dry air | air sec |
| demister | séparateurs de gouttelettes |

| EN | FR |
|-----------------------|---|
| overvoltage diode | Diode de surtension |
| unpiped | non tubé |
| variant | variante |
| valve | Valve |
| ventilator | ventilateur |
| volume flow control | contrôle du débit volumétrique |
| by | de |
| in front of | devant |
| at the front | avant |
| guard | Superviseur |
| heat exchanger | échangeur thermique |
| warning | mise en garde |
| water valve | vanne d'eau |
| change | Changer |
| white | Blanc |
| resistor | résistance |
| selector switch NO | Interrupteur trois position marche / arrêt / auto |
| time relay | relais temporisé |
| time relay on-delayed | relais temporisé retarde |
| | |



TR 570 / TR 830 / TR 1100 Desiccant Dehumidifier Limited Warranty

Warrantor:

Therma-Stor LLC
4201 Lien Rd
Madison, WI 53704
Telephone: 1-800-533-7533

Who Is Covered: This warranty extends only to the original end-user of the TR 570 / TR 830 / TR 1100 Desiccant Dehumidifier, and may not be assigned or transferred.

One Year Warranty: Therma-Stor LLC warrants that, for one (1) year the TR 570 / TR 830 / TR 1100 Desiccant Dehumidifier will operate free from any defects in materials and workmanship, or Therma-Stor LLC will, at its option, repair or replace the defective part(s), free of any charge.

End-User Responsibilities: Warranty service must be performed by a Servicer authorized by Therma-Stor LLC. If the end-user is unable to locate or obtain warranty service from an authorized Servicer, the end-user should call Therma-Stor LLC at the above number and ask for the Therma-Stor Service Department., which will then arrange for covered warranty service. Warranty service will be performed during normal working hours.

The end-user must present proof of purchase (lease) upon request, by use of the warranty card or other reasonable and reliable means. The end-user is responsible for normal care. This warranty does not cover any defect, malfunction, etc. resulting from misuse, abuse, lack of normal care, corrosion, freezing, tampering, modification, unauthorized or improper repair or installation, accident, acts of nature or any other cause beyond Therma-Stor LLC' reasonable control.

Limitations and Exclusions: If any TR 570 / TR 830 / TR 1100 Desiccant Dehumidifier part is repaired or replaced, the new part shall be warranted for only the remainder of the original warranty period applicable thereto (but all warranty periods will be extended by the period of time, if any, that the TR 570 / TR 830 / TR 1100 Desiccant Dehumidifiers is out of service while awaiting covered warranty service).

UPON THE EXPIRATION OF THE WRITTEN WARRANTY APPLICABLE TO THE TR 570 / TR 830 / TR 1100 DESICCANT DEHUMIDIFIER OR ANY PART THEREOF, ALL OTHER WARRANTIES IMPLIED BY LAW, INCLUDING MERCHANTABILITY AND FITNESS FOR A PARTICULAR PURPOSE, SHALL ALSO EXPIRE. ALL WARRANTIES MADE BY THERMA-STOR LLC ARE SET FORTH HEREIN, AND NO CLAIM MAY BE MADE AGAINST THERMA-STOR LLC BASED ON ANY ORAL WARRANTY. IN NO EVENT SHALL THERMA-STOR LLC, IN CONNECTION WITH THE SALE, INSTALLATION, USE, REPAIR OR REPLACEMENT OF ANY TR 570 / TR 830 / TR 1100 DESICCANT DEHUMIDIFIER OR PART THEREOF BE LIABLE UNDER ANY LEGAL THEORY FOR ANY SPECIAL, INDIRECT OR CONSEQUENTIAL DAMAGES INCLUDING WITHOUT LIMITATION WATER DAMAGE (THE END-USER SHOULD TAKE PRECAUTIONS AGAINST SAME), LOST PROFITS, DELAY, OR LOSS OF USE OR DAMAGE TO ANY REAL OR PERSONAL PROPERTY.

Some states do not allow limitations on how long an implied warranty lasts, and some do not allow the exclusion or limitation of incidental or consequential damages, so one or both of these limitation may not apply to you.

Legal Rights: This warranty gives you specific legal rights, and you may also have other rights which vary from state to state.